

- Montageanleitung
- Assembly instructions
- Notice de montage
- Montagehandleiding
- Návod na montáž
- Instrucțiune de montaj
- Navodila za namestitev
- Installationstruktioener



Schraubtechnik / Profile drilling method / fixation à percer / Schroef techniek

Seite / Page / page / Pagina 2 - 11



Klebetchnik / bonding technique / fixation à coller / verlijm techniek

Seite / Page / page / Pagina 12 - 25

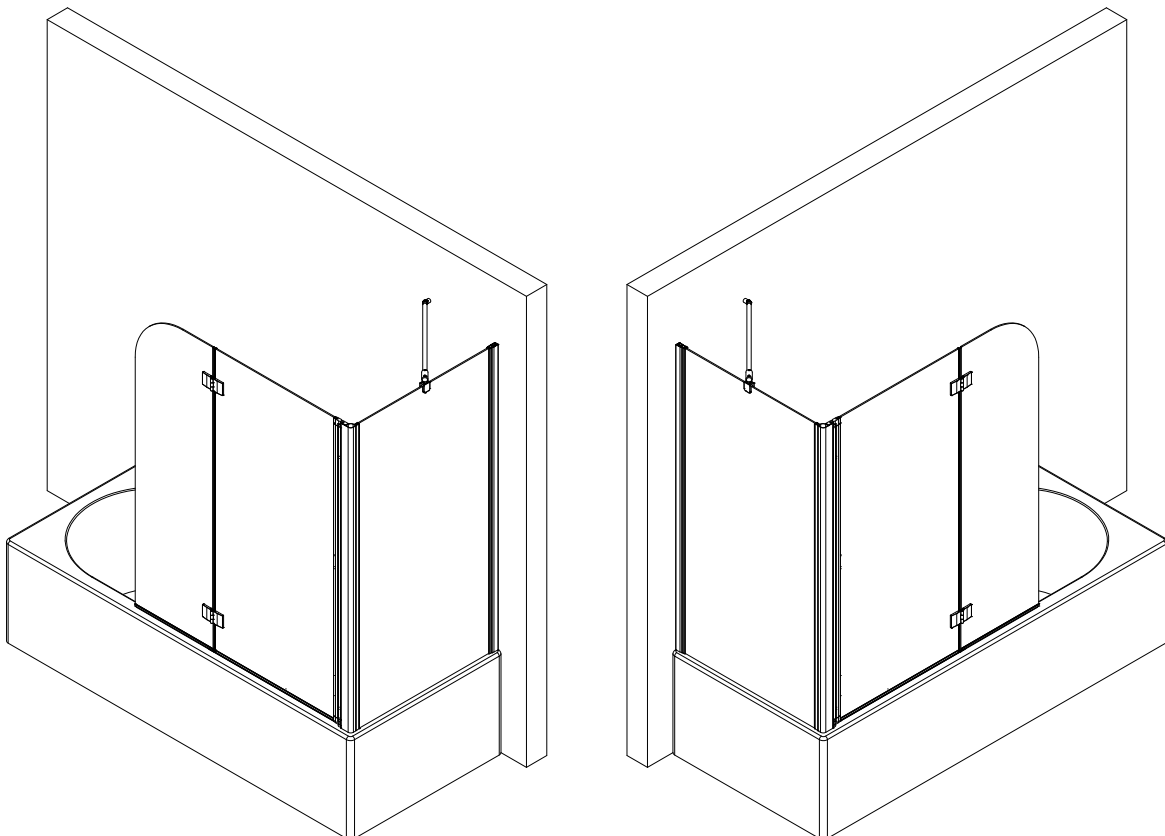

**de** Standard: Montage links. Bei rechts Montage ist das Dekor auf der Innenseite.

**en** Standard: installation on the left. When mounted on the right, the decor is on the inside.

**fr** Standard: montage à gauche. En cas de montage à droite, le décor est à l'intérieur.

**nl** Sandaard: Montage aan de linkerkant. Bij montage aan de rechterkant zit het decor aan de binnenkant.

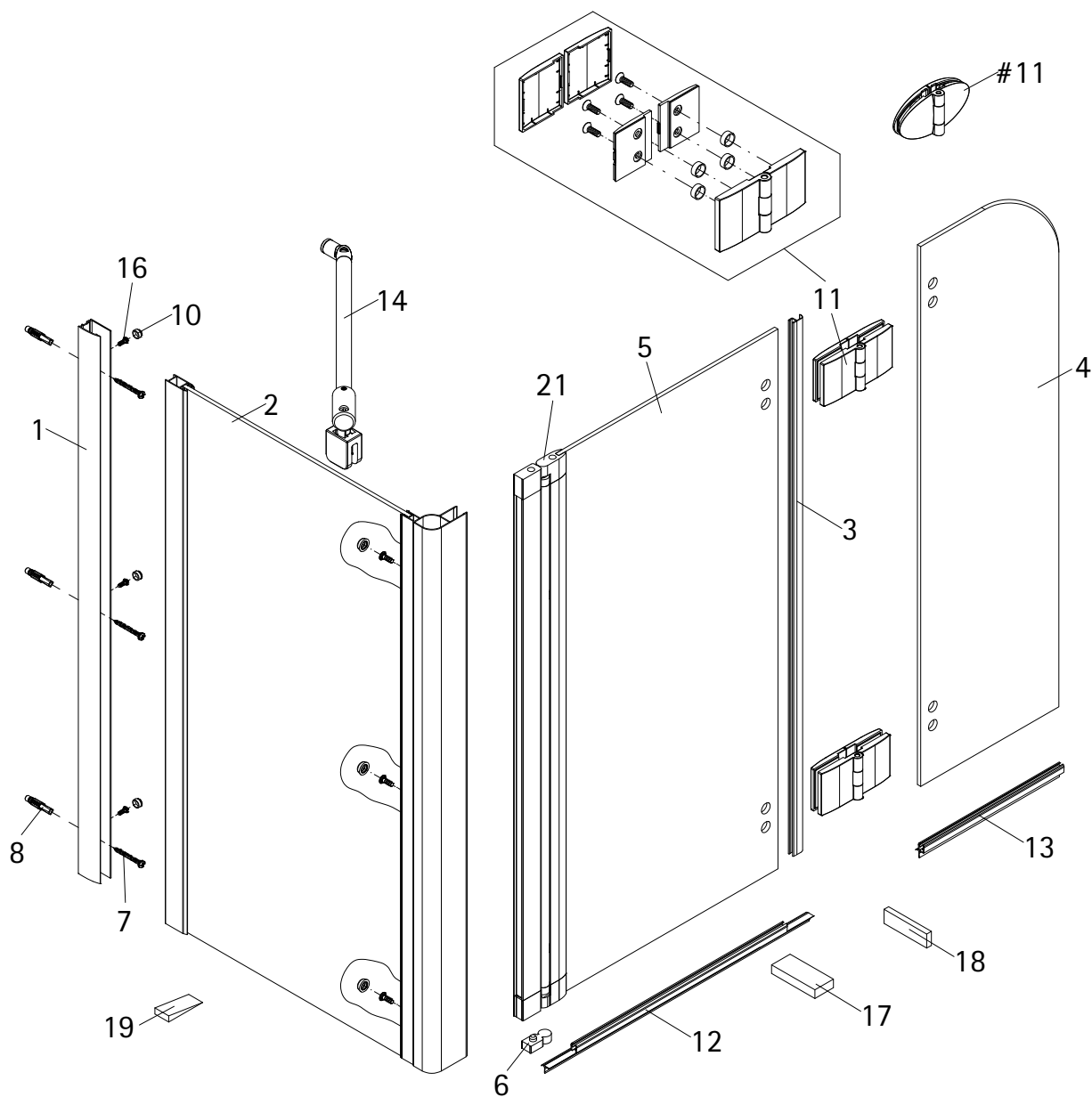

Pos.	Bezeichnung	Ersatzteil-Nr.	Preis	Pos.	Bezeichnung	Ersatzteil-Nr.	Preis
1	1x Wandanschlussprofil	E100230-6	Stück 86,95 €	12	1x Wasserabweisprofil	E100058-5-2	Stück 23,00 €
2	1x Seitenwand			13	1x Wasserabweisprofil	E100058-5-2	Stück 23,00 €
3	1x Dichtung	E22070-1	Stück 24,95 €	14	1x Stabilisationsbügel, komplett	E100320	Stück 46,95 €
4	1x Scheibe Element 2			16*	6x Kappenschraube 3,5 x 9,5 mm		
5	1x Scheibe Element 1			17	2x Montagehilfe 9 x 20 x 60 mm	E100201-8	Set 12,00 €
6	1x Unterlegteil	E100080	Stück 9,95 €	18	2x Montagehilfe 10 x 15 x 70 mm	E100201-12	Set 12,00 €
7*	3x Linsen-Blechkopfschraube 4,2 x 45 mm			19	1x Silikonkeile (6 Stück)	E100203	Set 16,95 €
8*	3x Dübel			20	2x Drehlager Komplett (inkl. Pos. 6)	E100082-8	Set pro Seite 19,95 €
10*	6x Abdeckkappe für Kappenschraube						
11#	2x Scharnier eckig, komplett	E100290-22	Stück 62,00 €		* Schrauben- und Abdeckkappenset	E22200-2	16,95 €
11#	2x Scharnier oval, komplett	E100290-21	Stück 62,00 €		# optional		

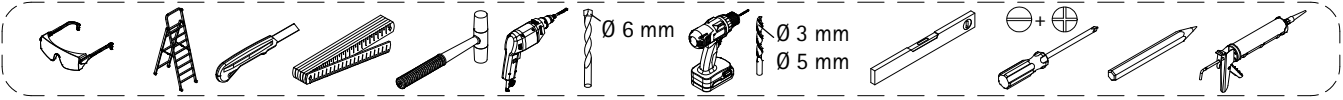
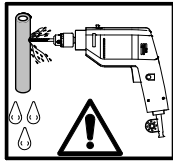
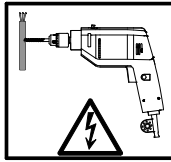
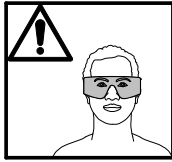
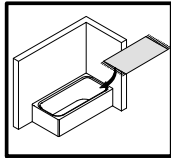

Schraubtechnik / Profile method / fixation à percer / Schroef techniek

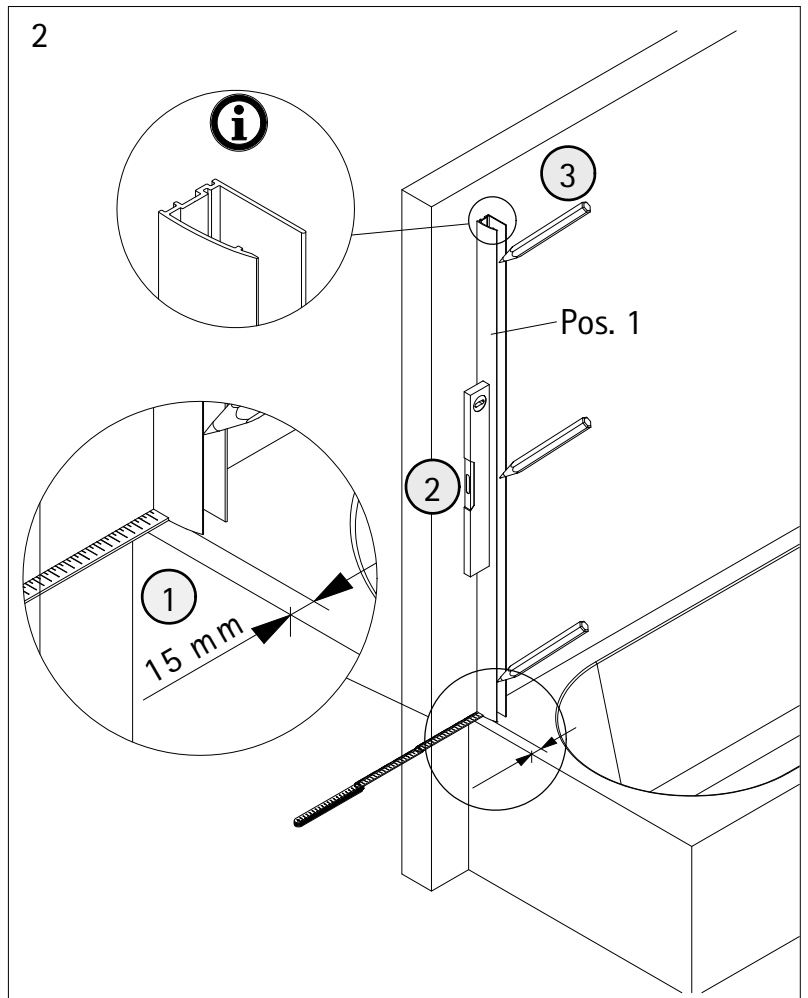
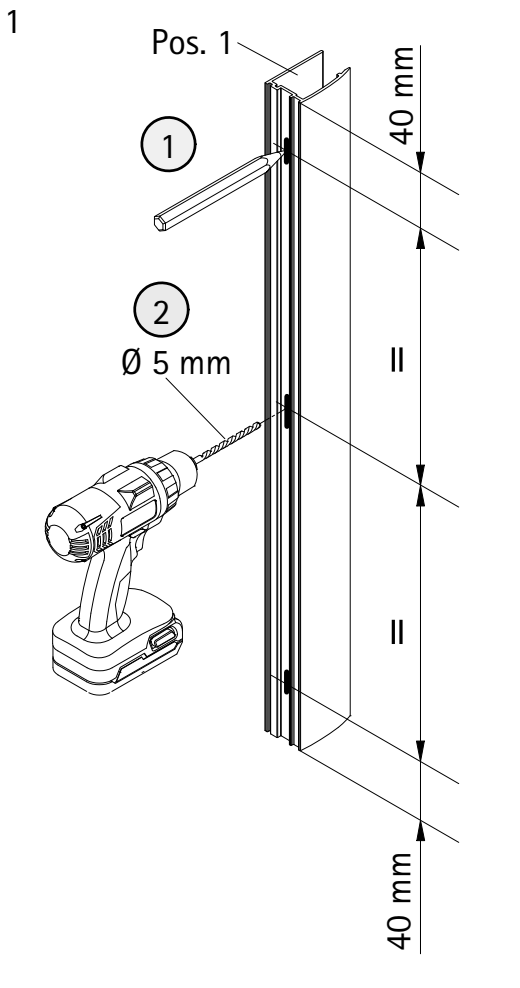
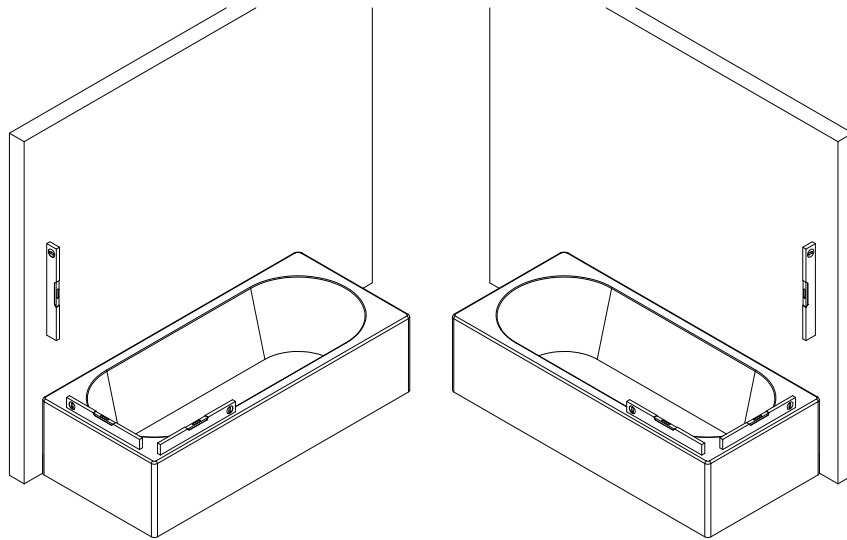

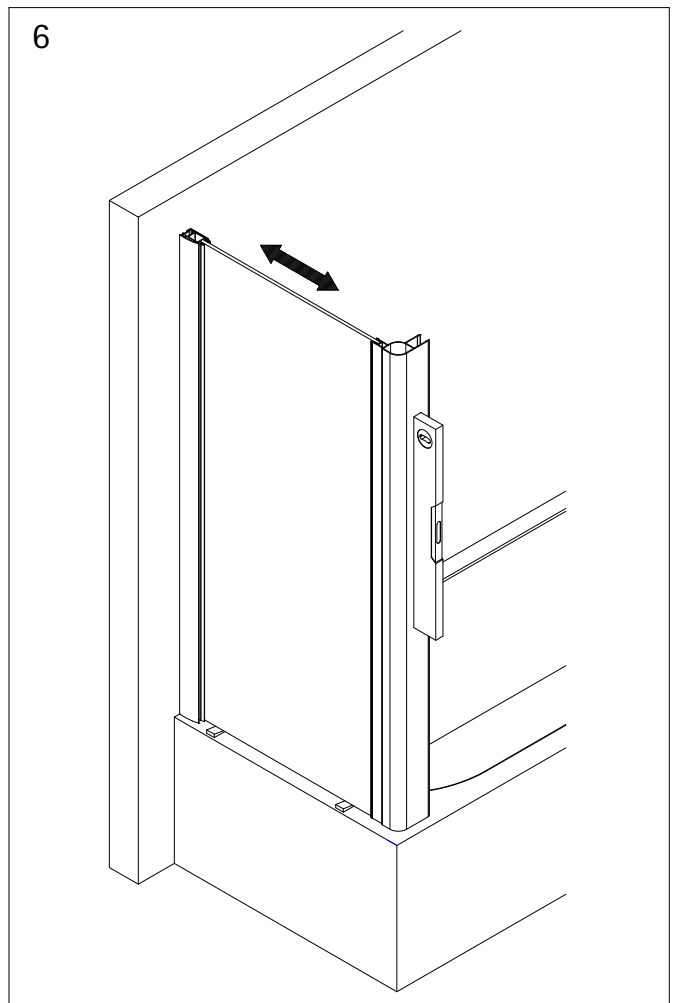
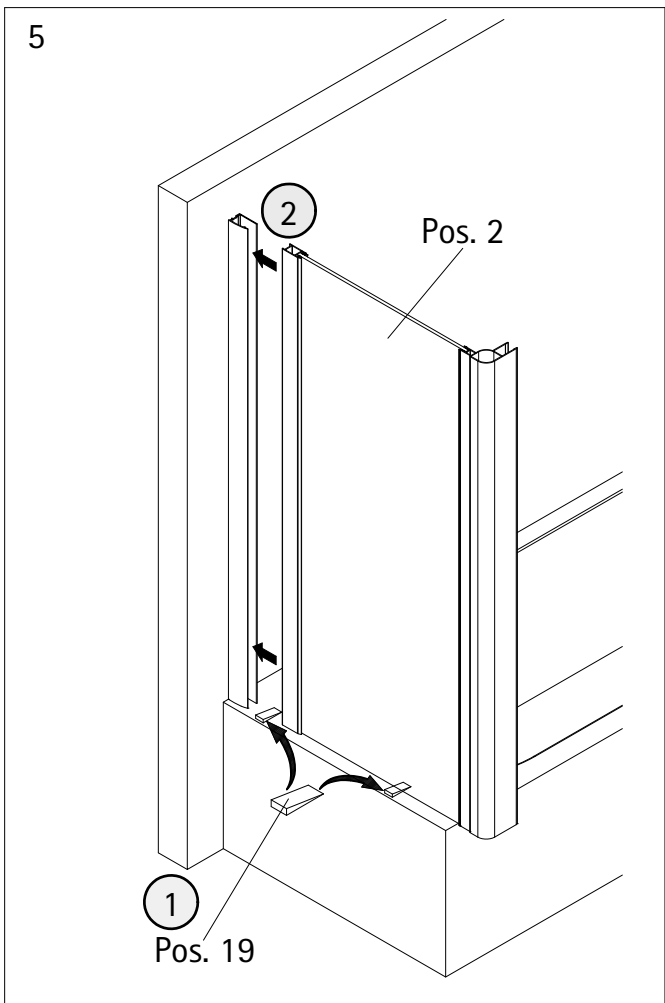
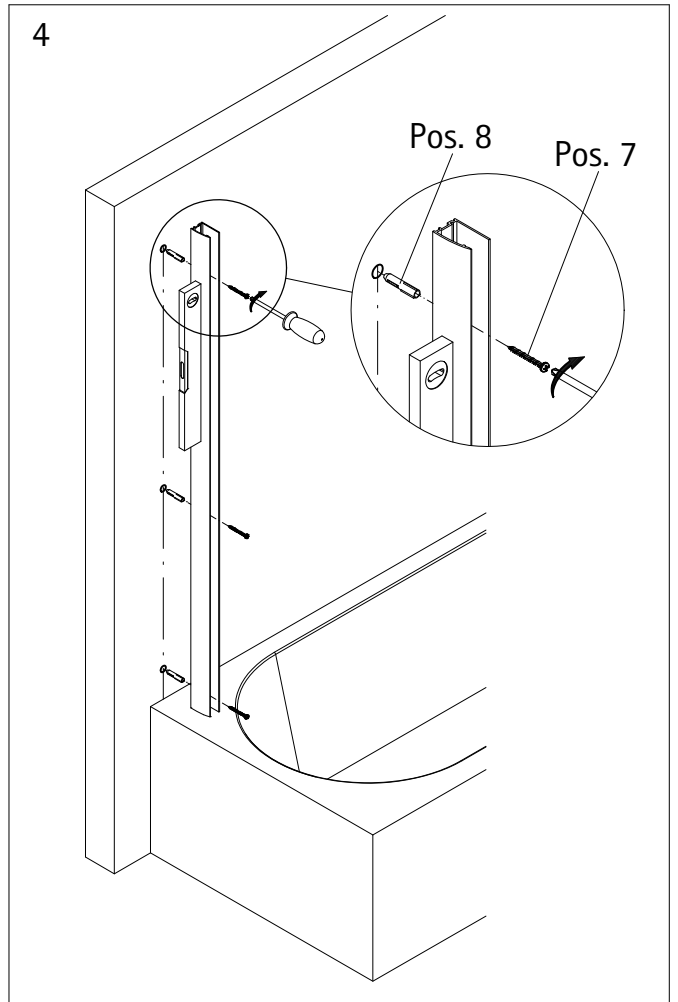
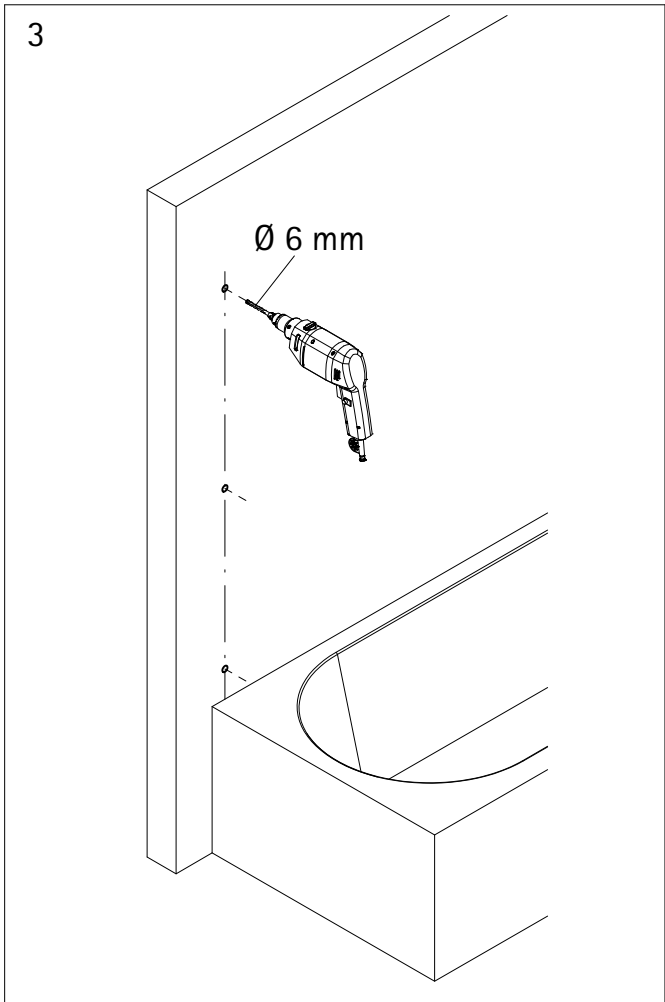

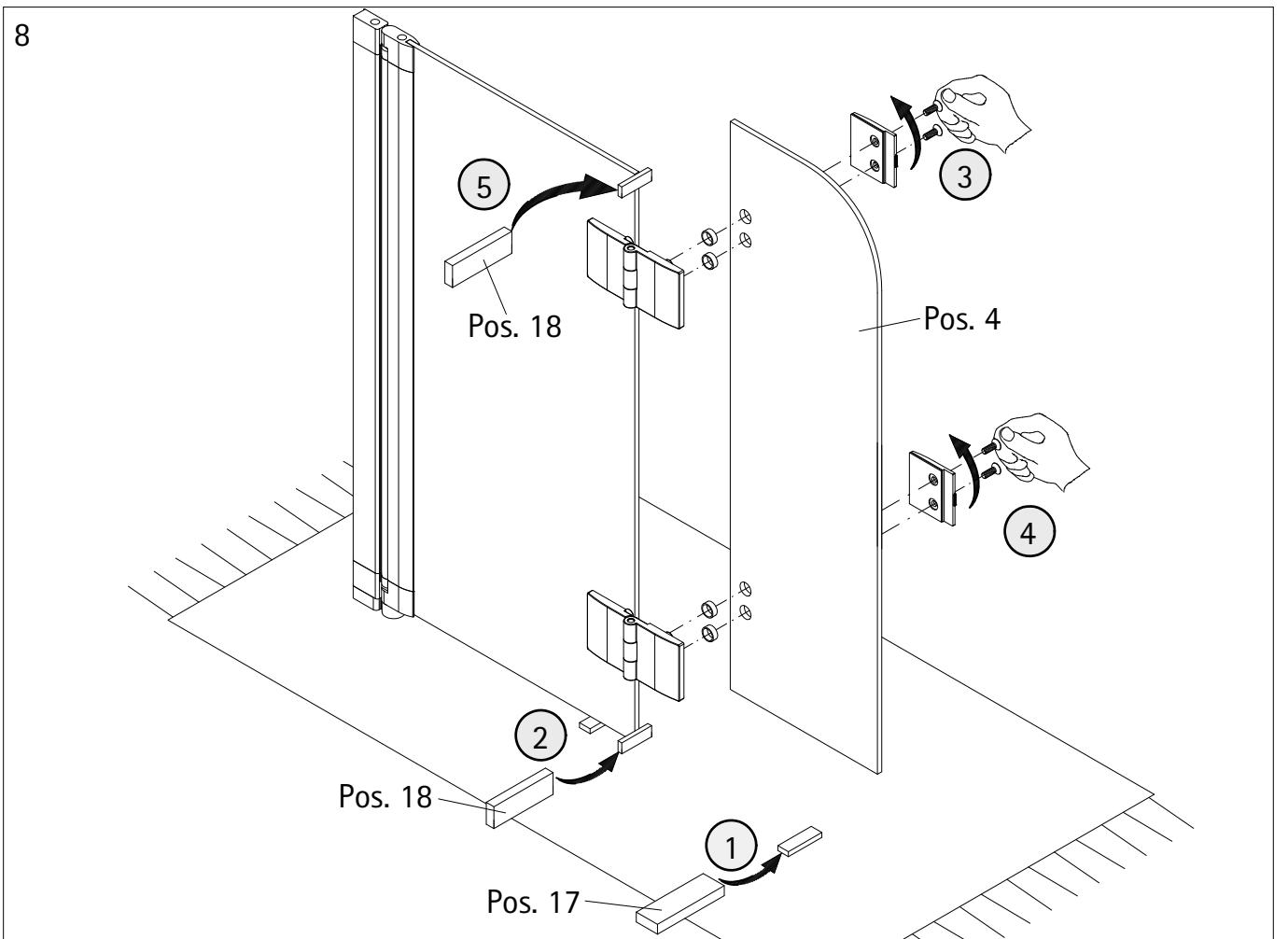
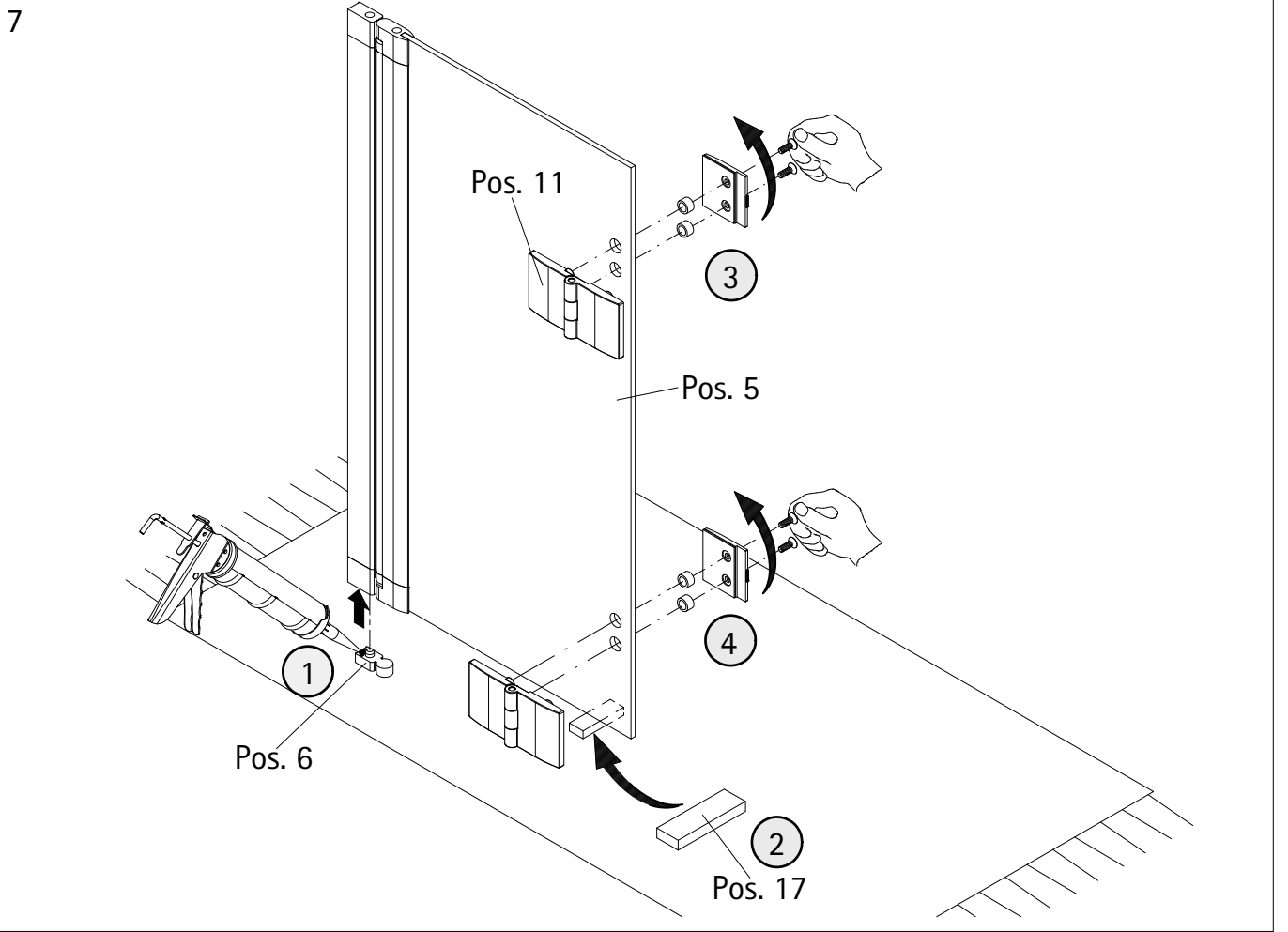

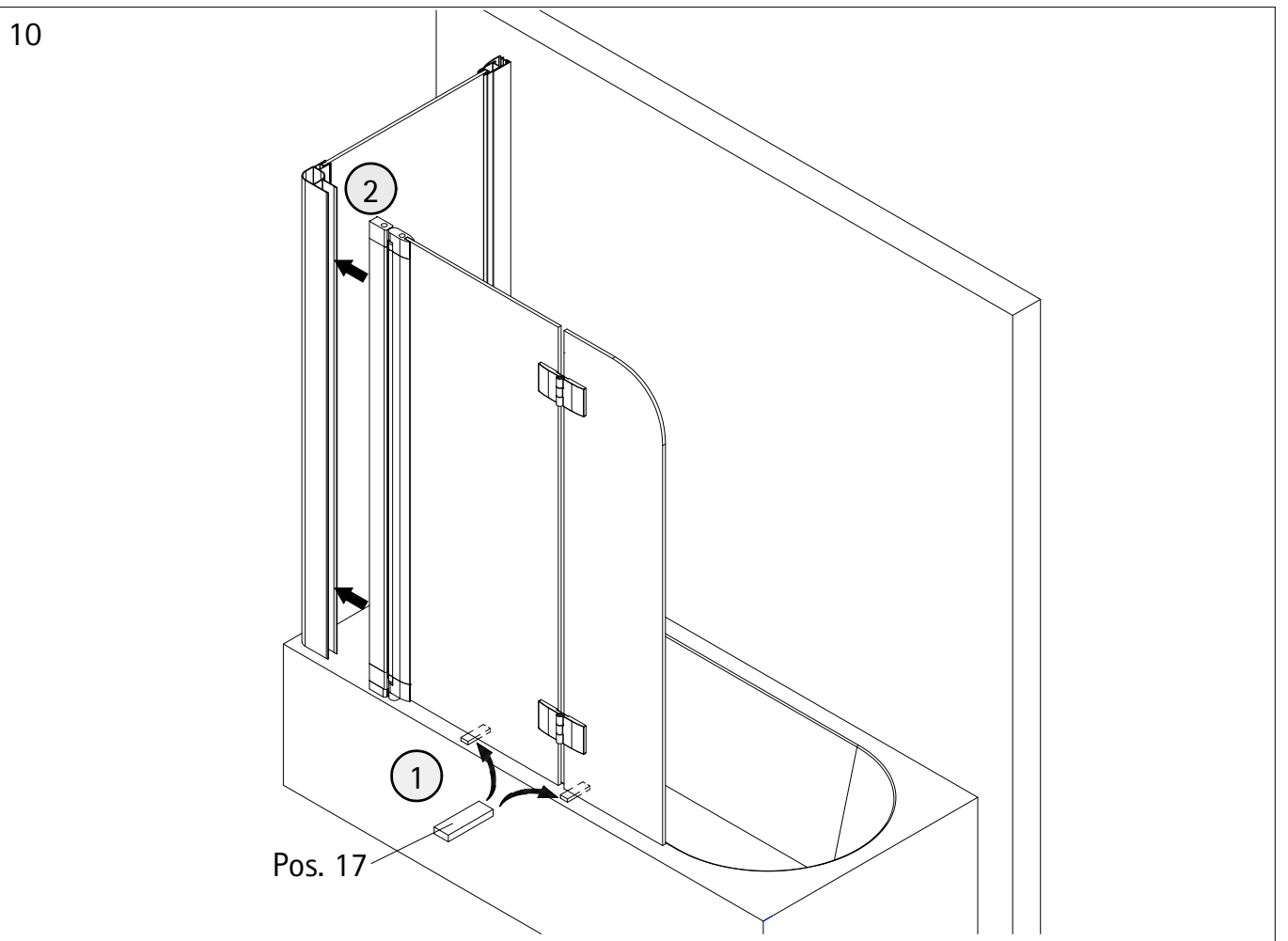
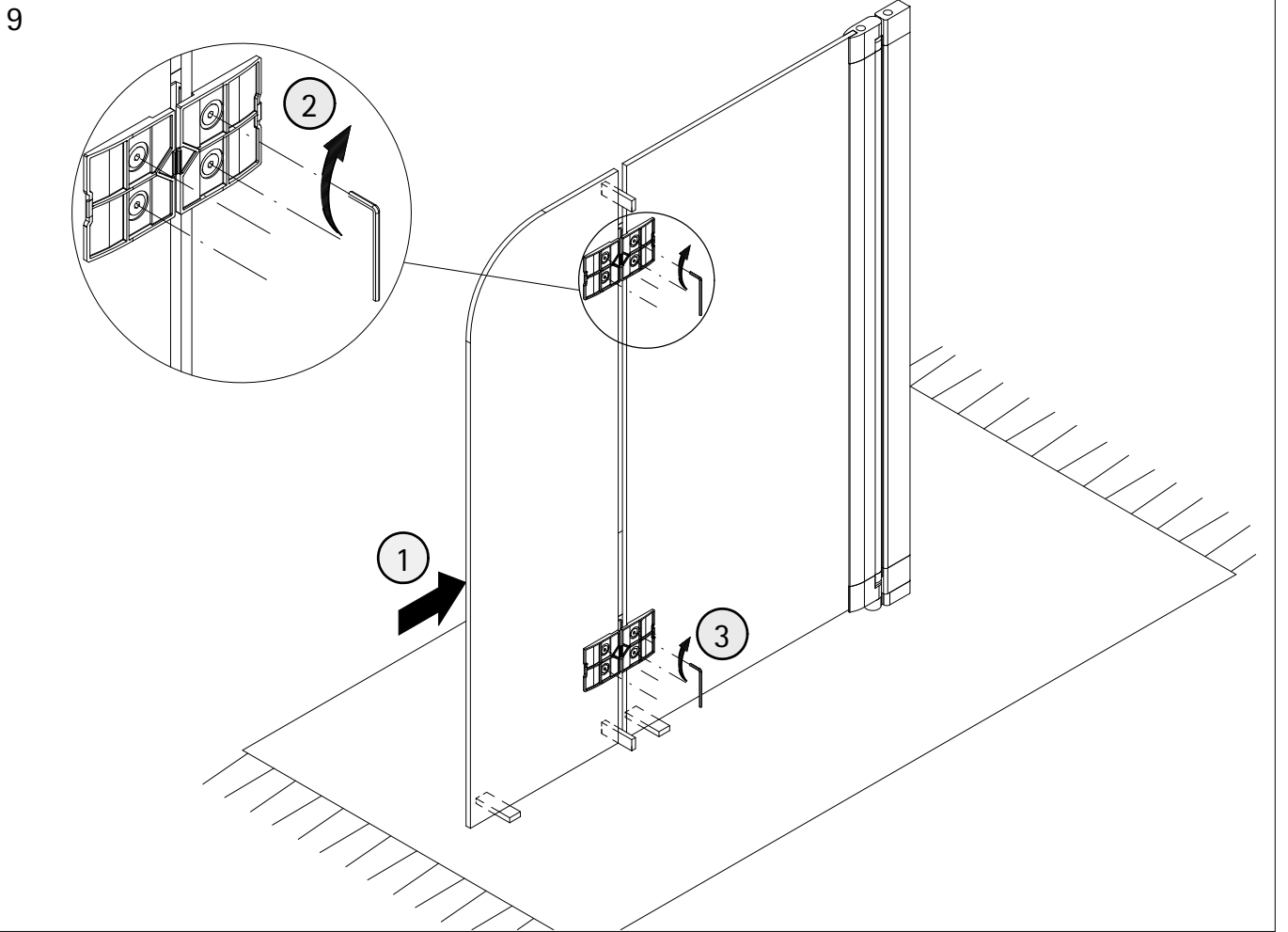

11

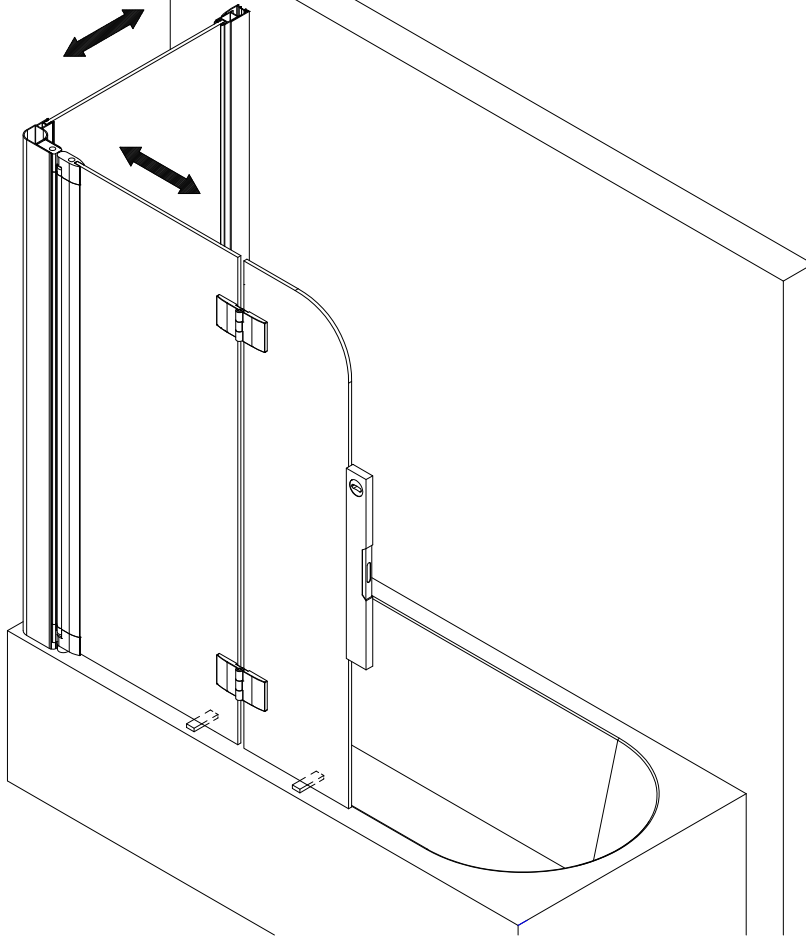

12

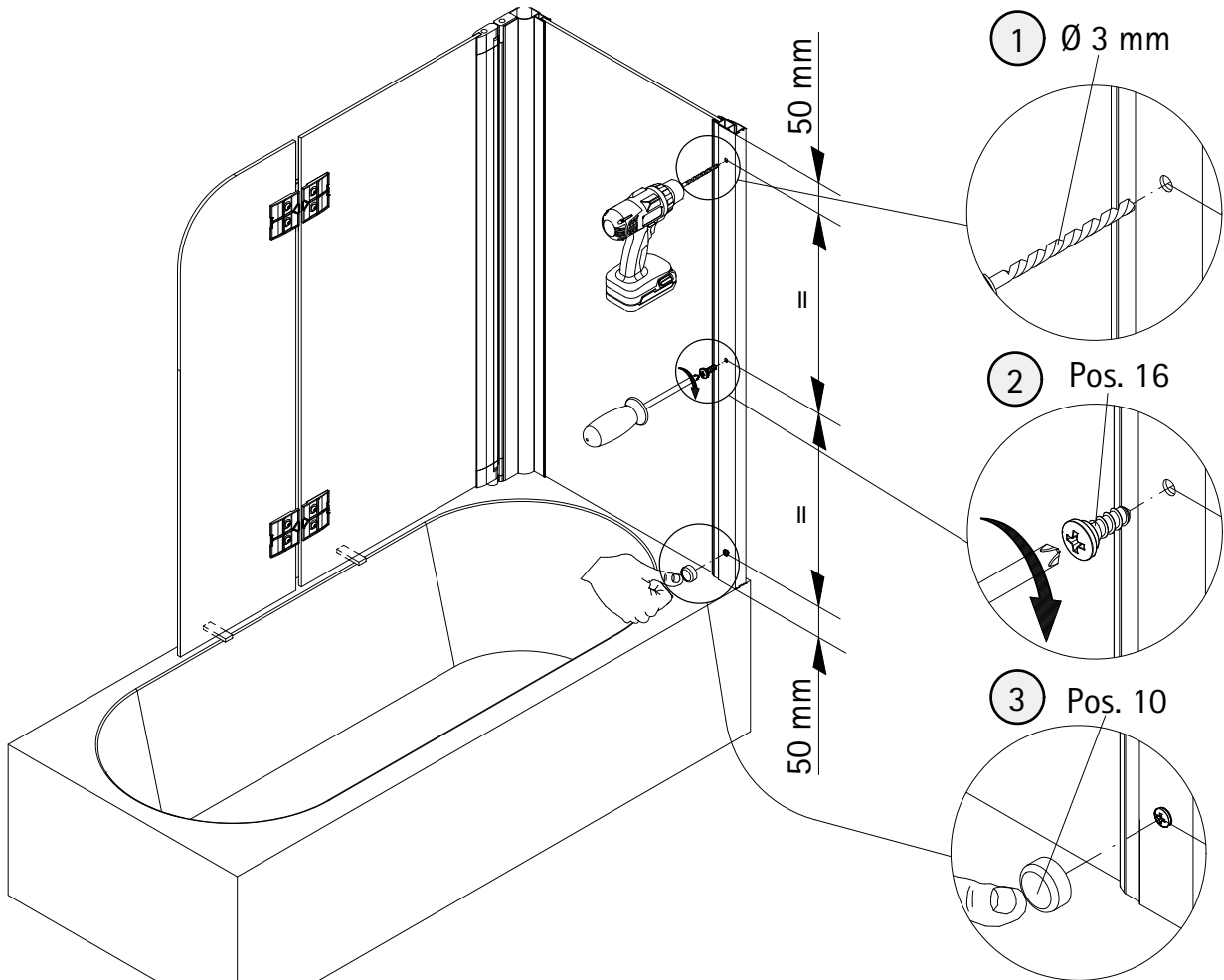

13

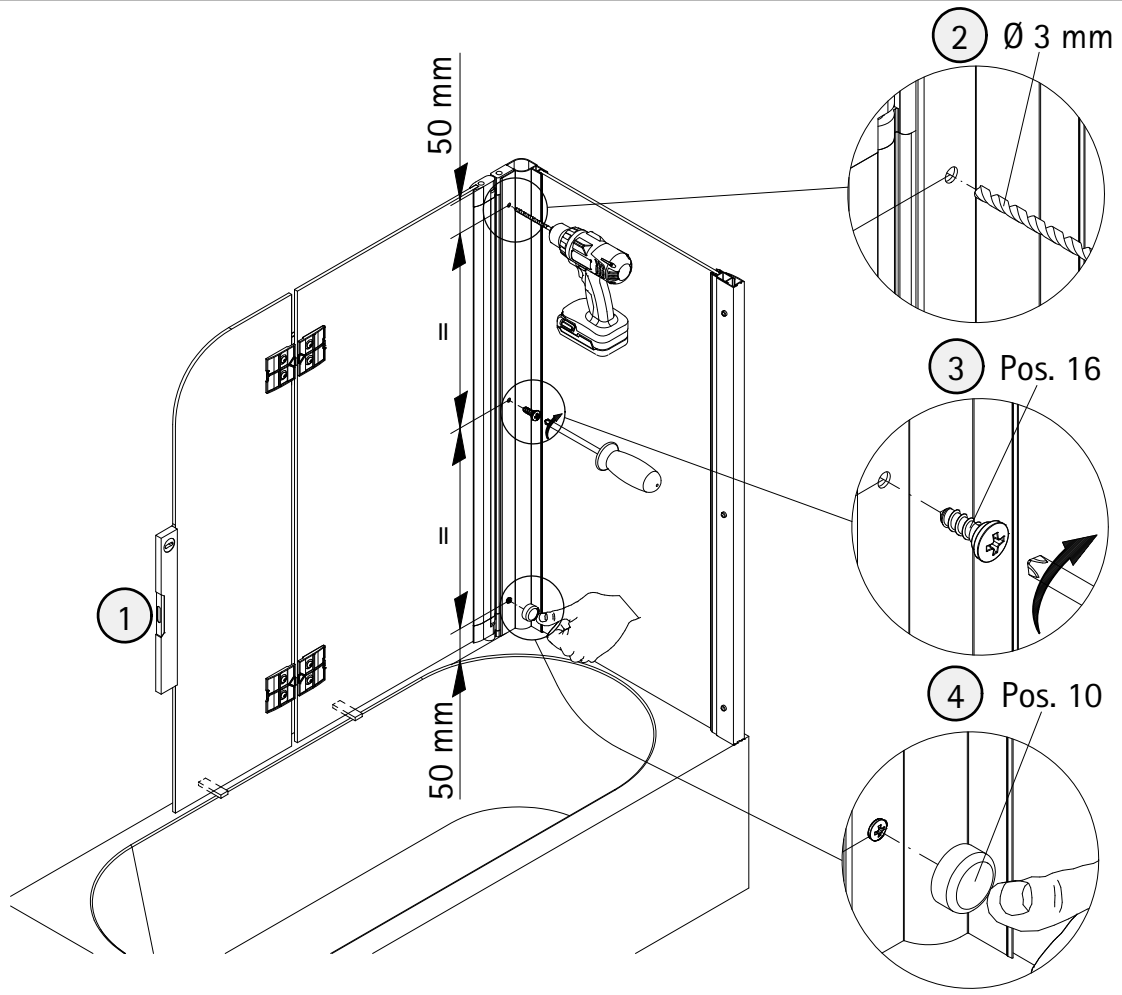

14

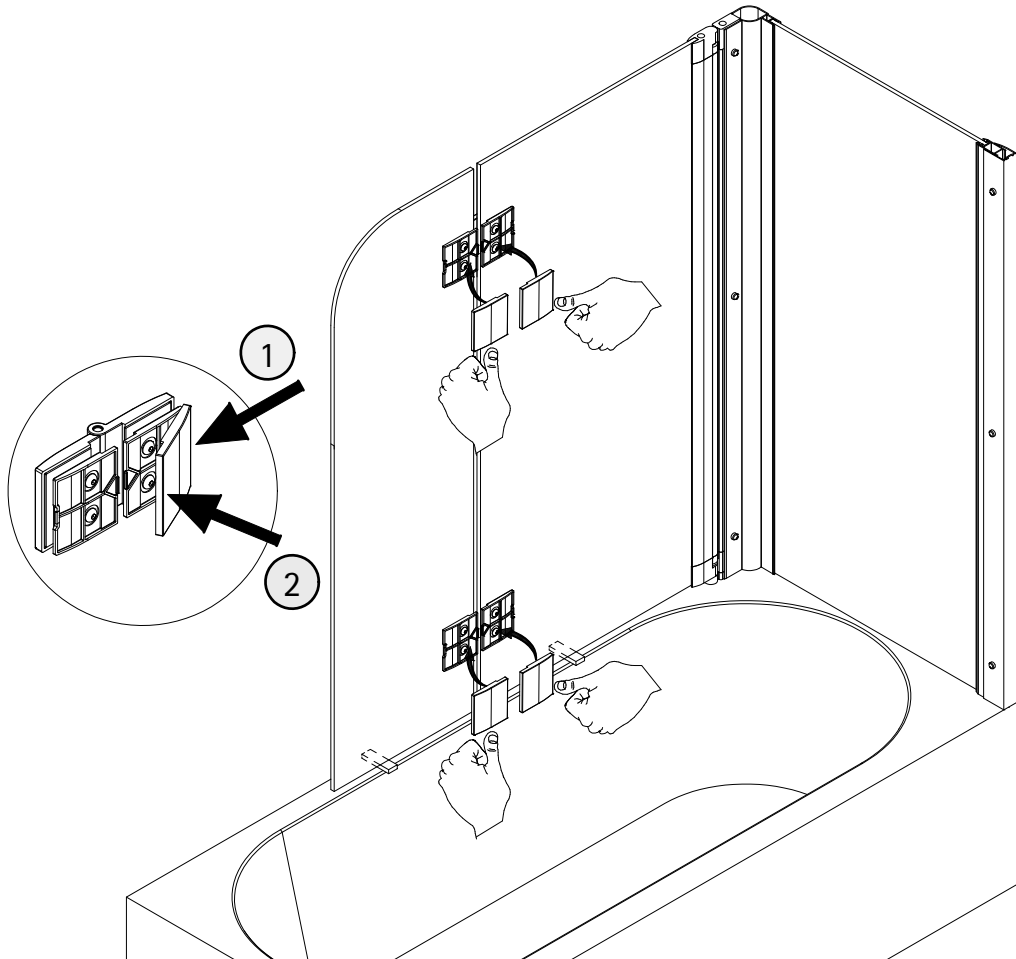



15

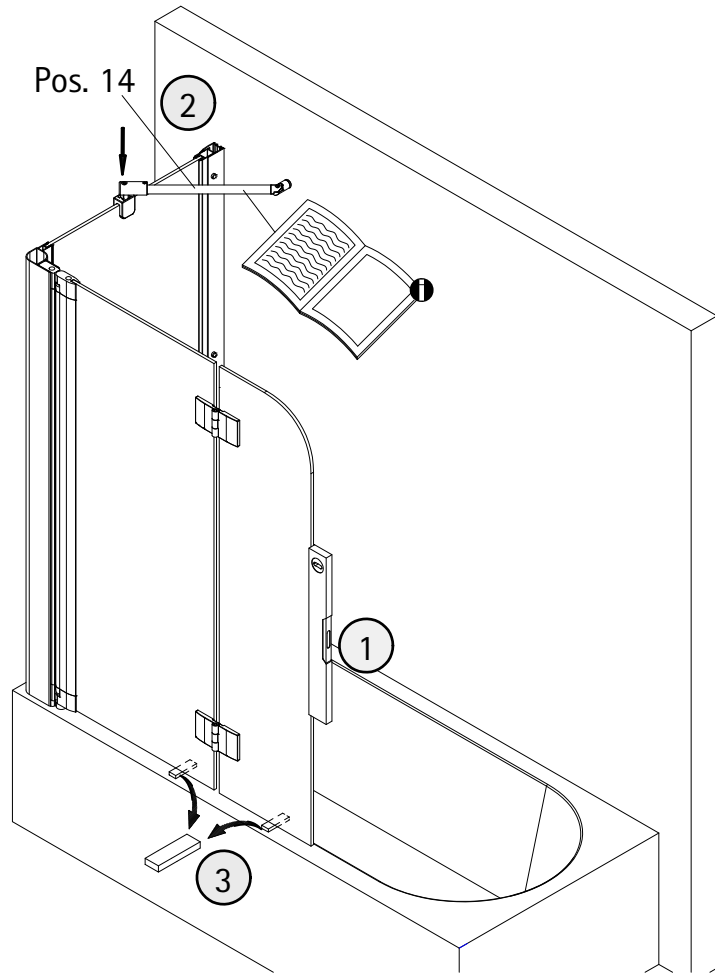

16

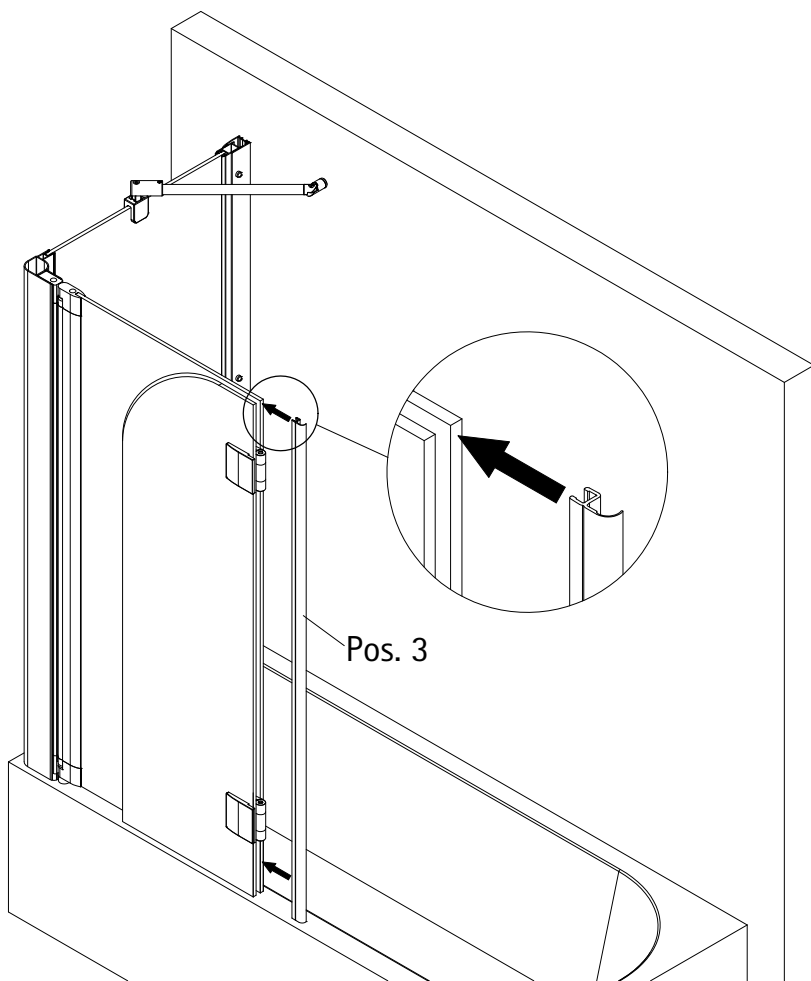

17

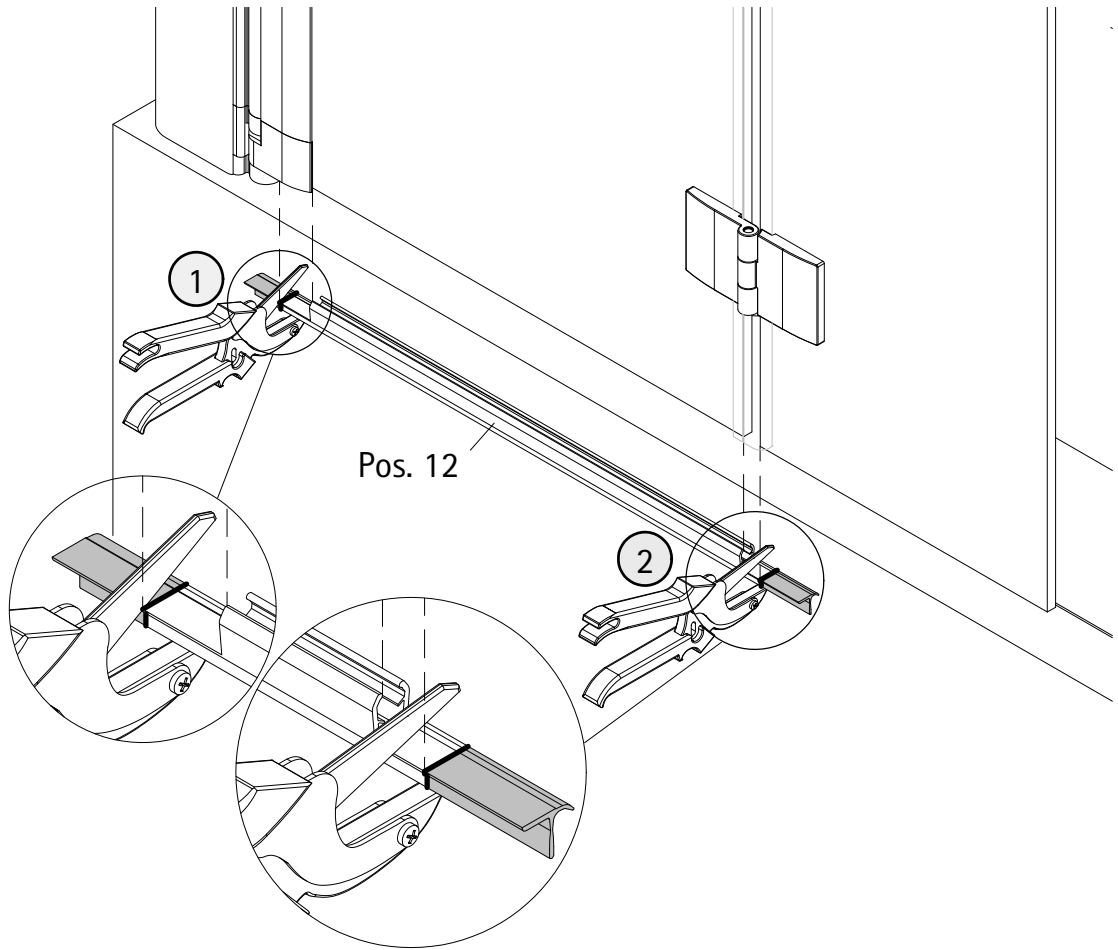

18

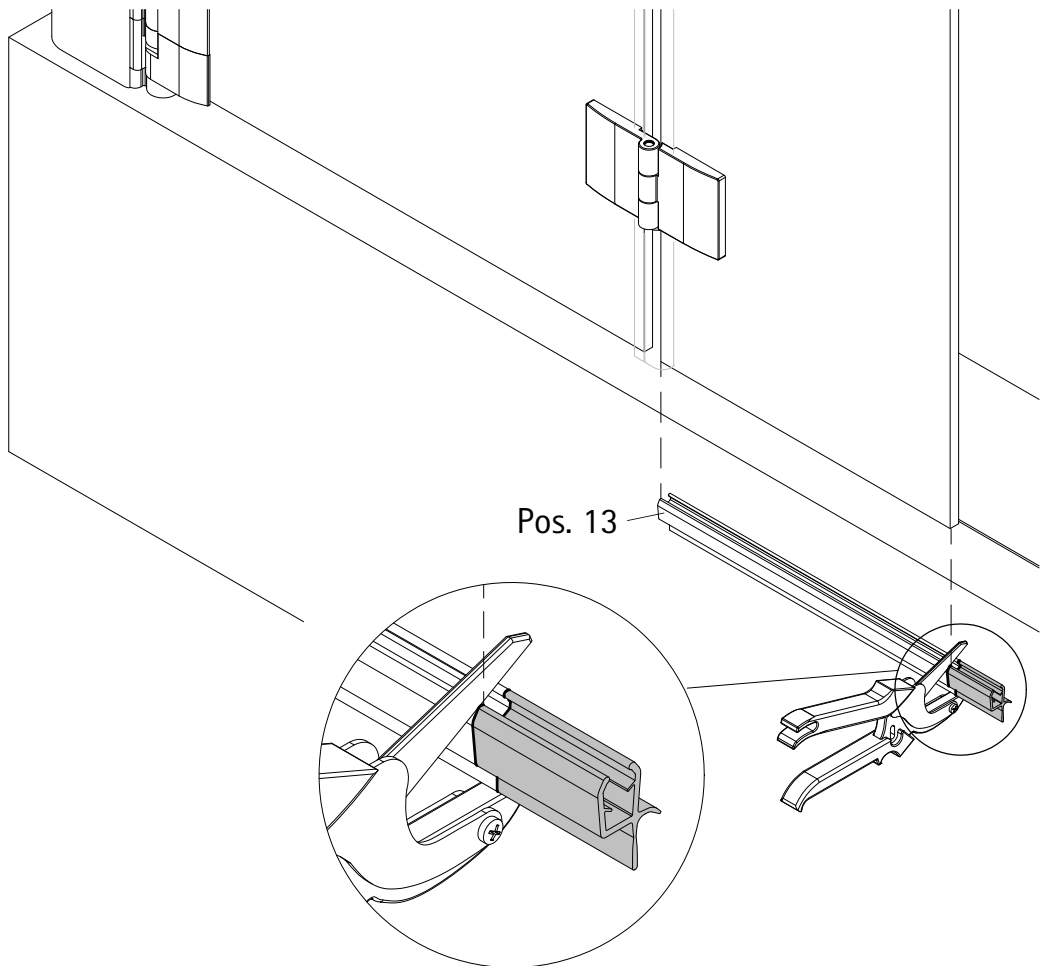

19

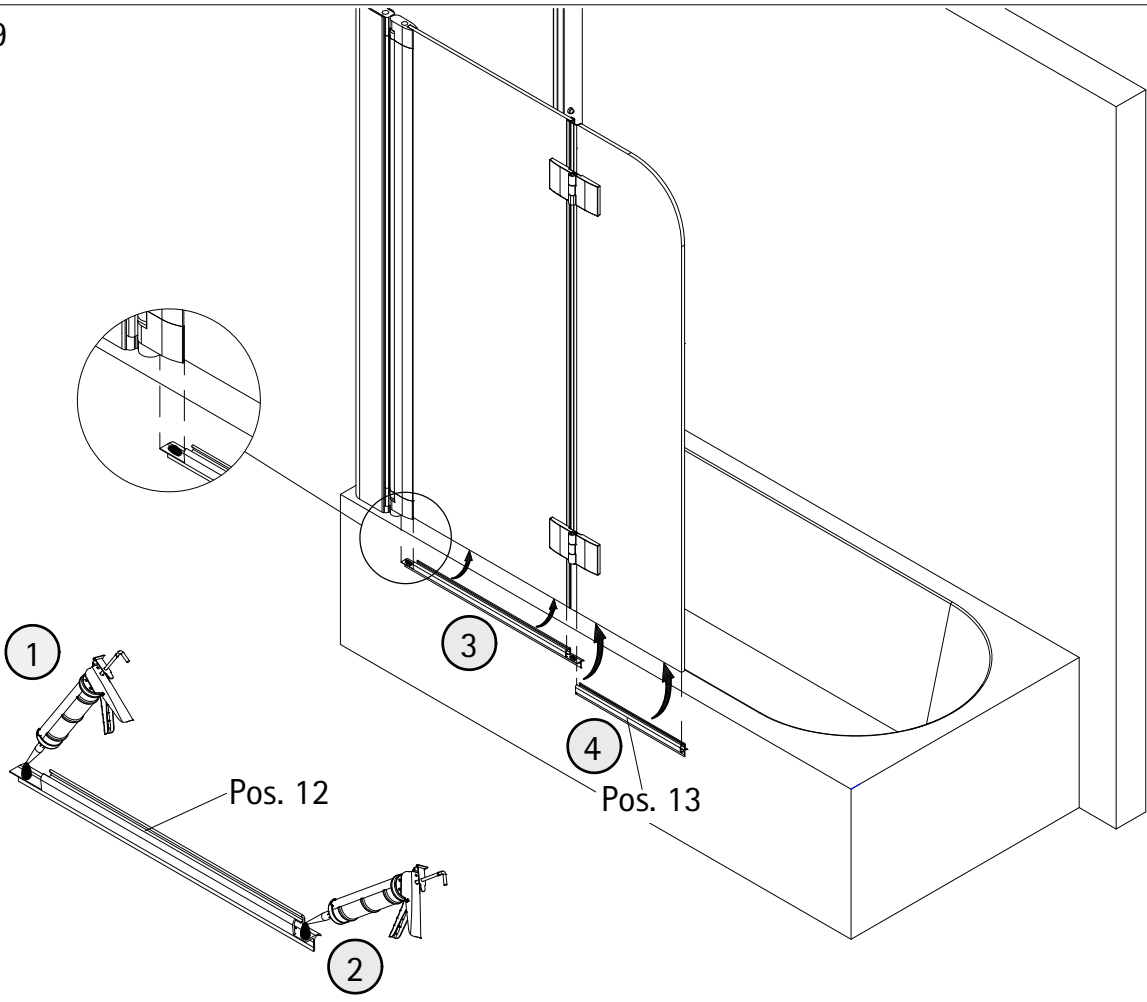

20

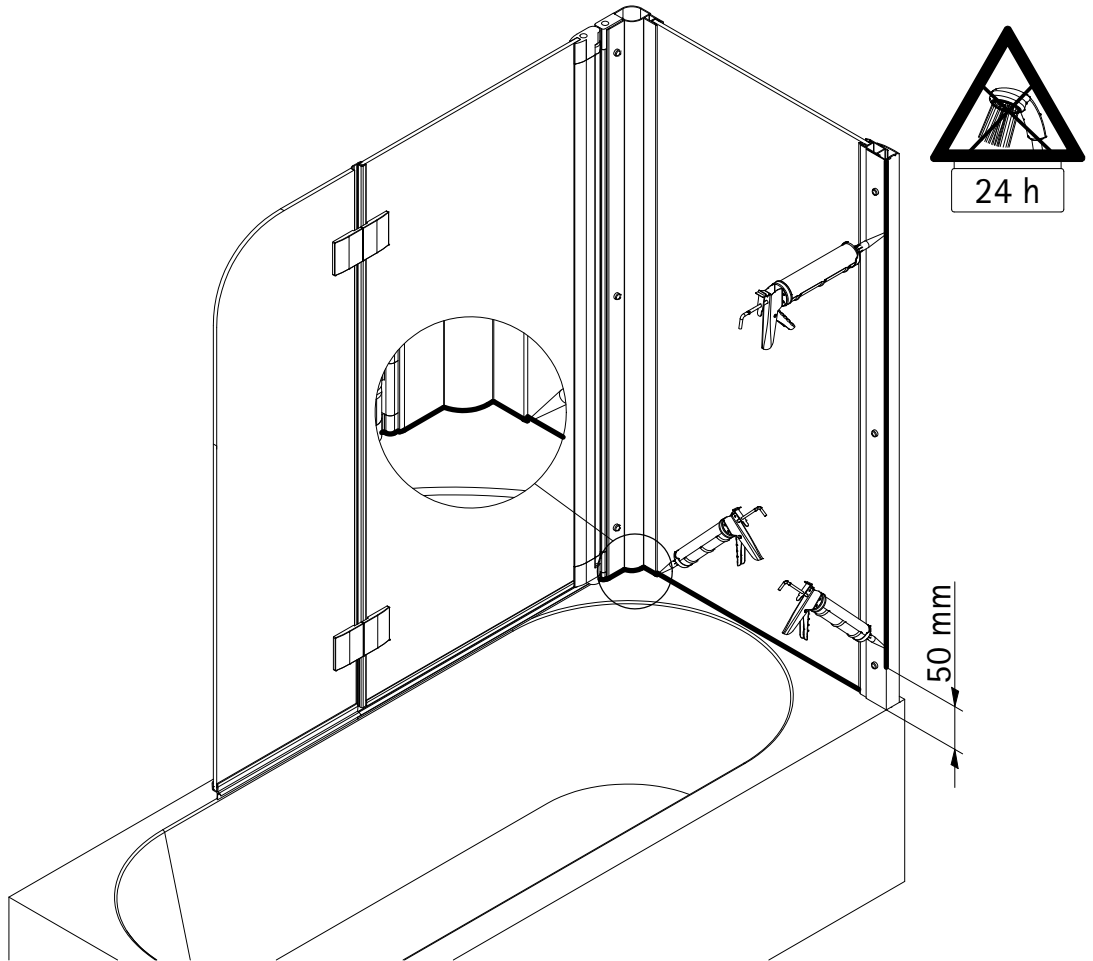

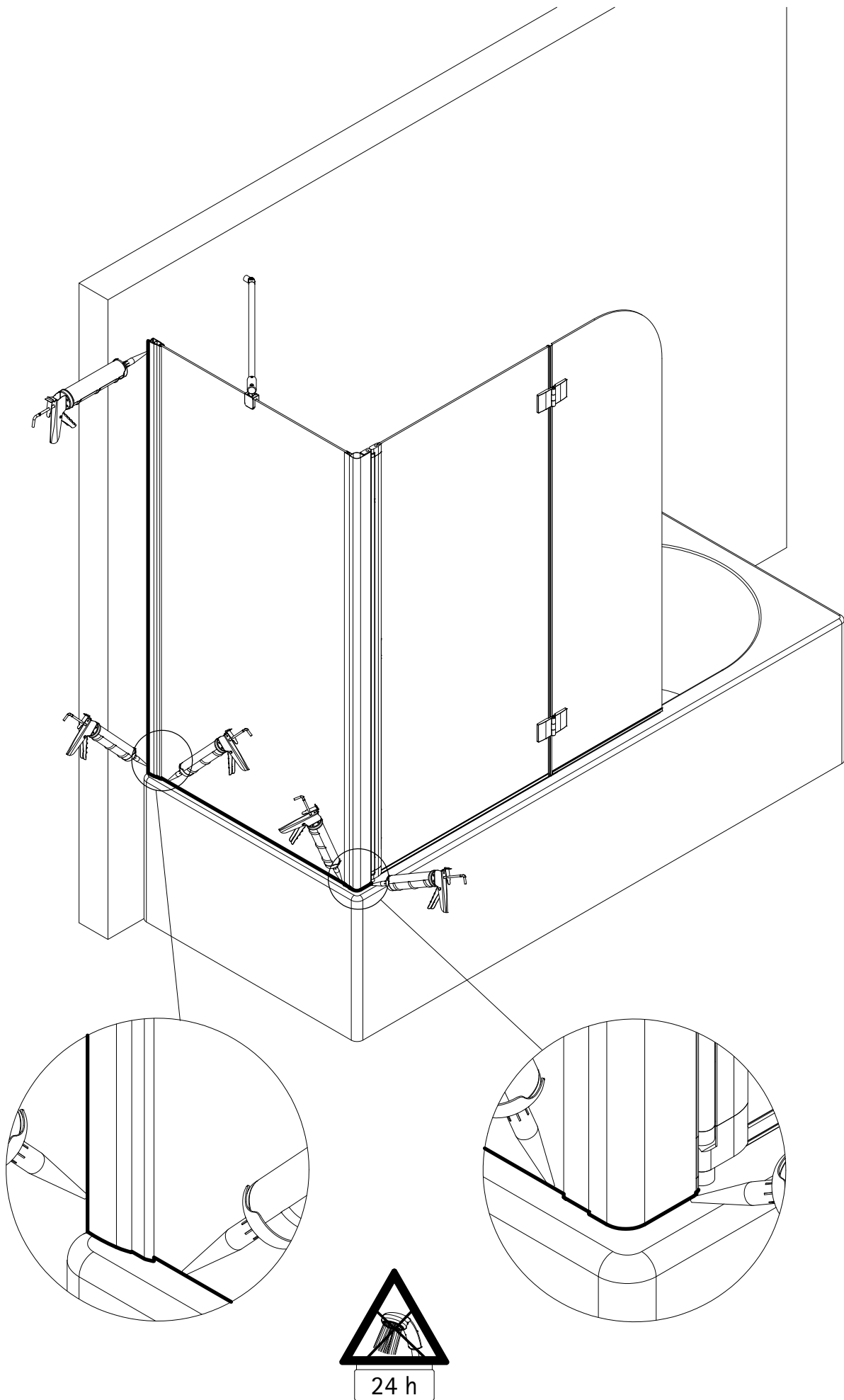

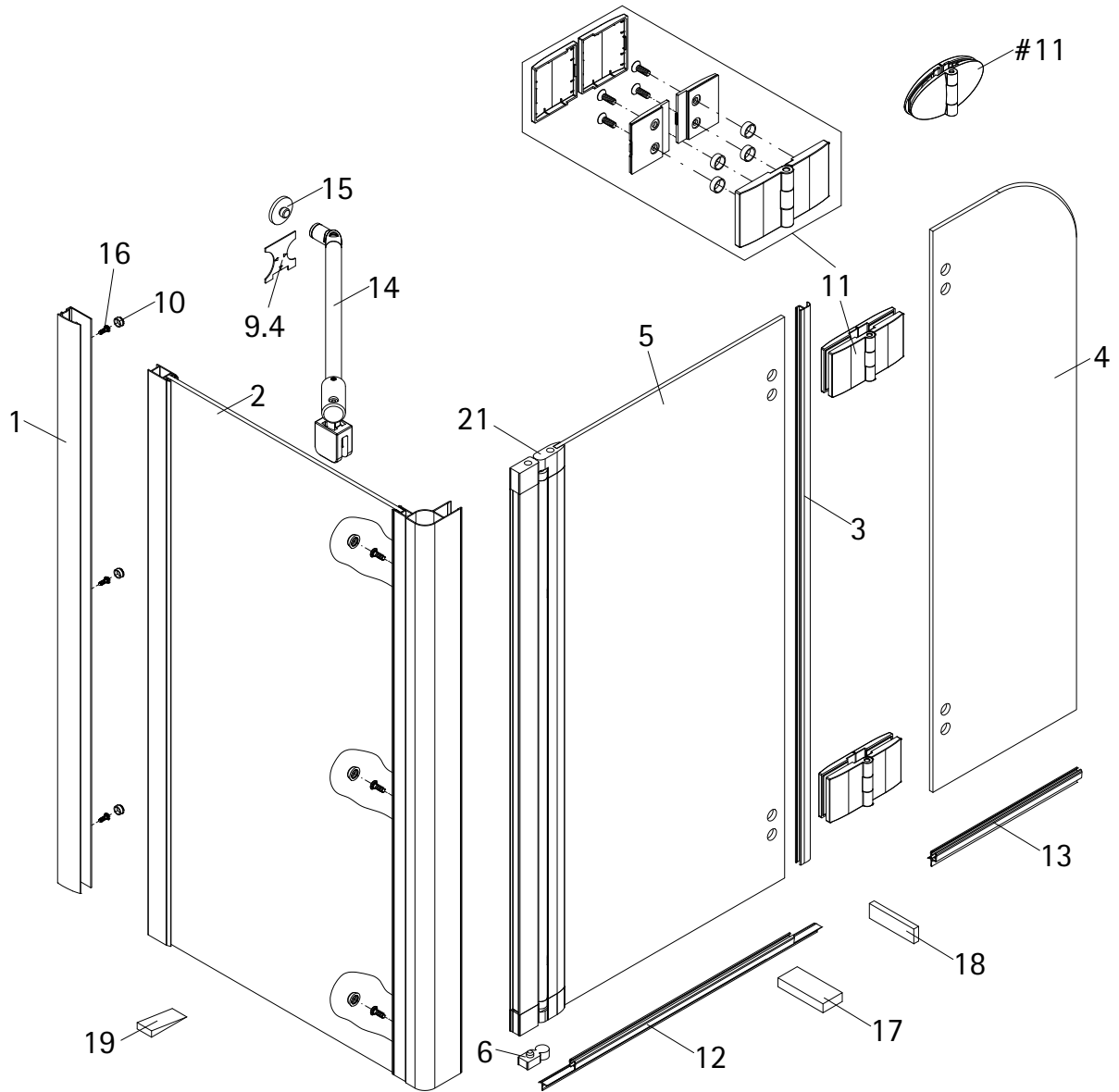

Pos.	Bezeichnung	Ersatzteil-Nr.	Stück	Preis
1	1x Wandanschlussprofil	E100230-6	Stück	86,95 €
2	1x Seitenwand			
3	1x Dichtung	E22070-1	Stück	24,95 €
4	1x Scheibe Element 2			
5	1x Scheibe Element 1			
6	1x Unterlegteil	E100080	Stück	9,95 €
9	1x Klebeset komplett			
9.1	2x Reinigungstuch			
9.2	3x Kleber			
9.3	1x Aufrollhilfe			
9.4	1x Montagehilfe			
10*	6x Abdeckkappe für Kappenschraube			
11#	2x Scharnier eckig, komplett	E100290-22	Stück	62,00 €
11#	2x Scharnier oval, komplett	E100290-21	Stück	62,00 €
12	1x Wasserabweisprofil	E100058-5-2	Stück	23,00 €
13	1x Wasserabweisprofil	E100058-5-2	Stück	23,00 €
14	1x Stabilisationsbügel, komplett	E100320	Stück	46,95 €
15	1x Adapter Stabilisationsbügel			
16*	6x Kappenschraube 3,5 x 9,5 mm			
17	2x Montagehilfe 9 x 20 x 60 mm	E100201-8	Set	12,00 €
18	2x Montagehilfe 10 x 15 x 70 mm	E100201-12	Set	12,00 €
19	1x Silikonkeile (6 Stück)	E100203	Set	16,95 €
21	2x Drehlager Komplett	E100082-8	Set pro Seite	19,95 €
	* Schrauben- und Abdeckkappenset	E22200-2		16,95 €
	# optional			

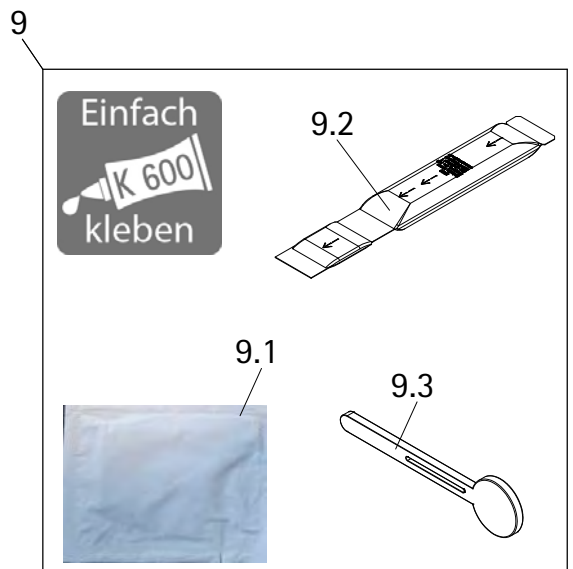

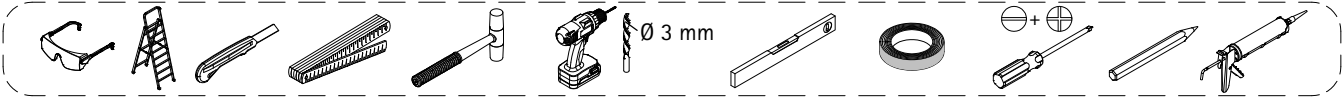
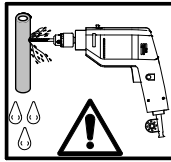
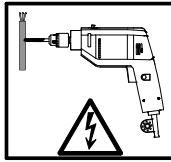
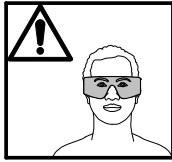
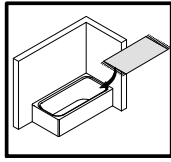
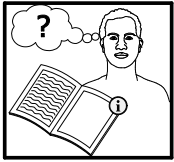

### Klebetchnik / bonding technique / fixation à coller / verlijm techniek

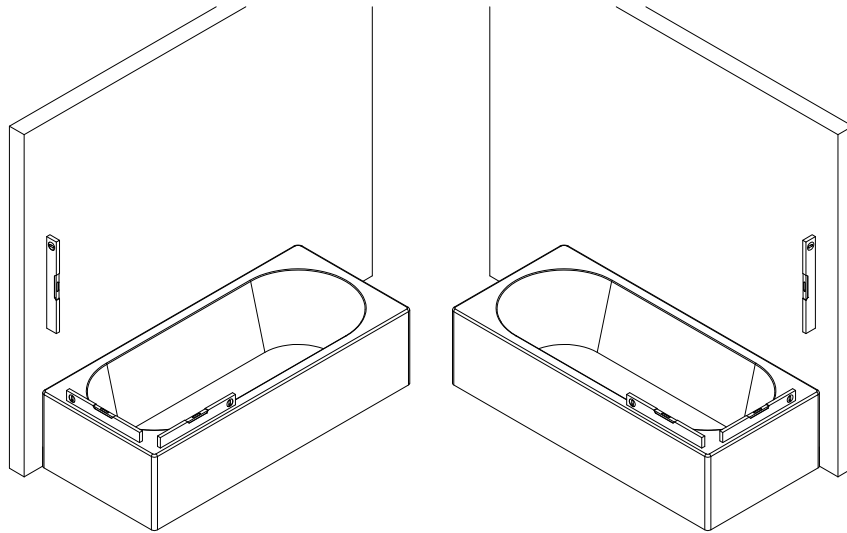

1



- Beipackzettel unbedingt beachten.
- Note: Read enclosed instruction leaflet carefully
- Veuillez impérativement faire attention à la notice explicative.
- Let op: les de bijsluiter

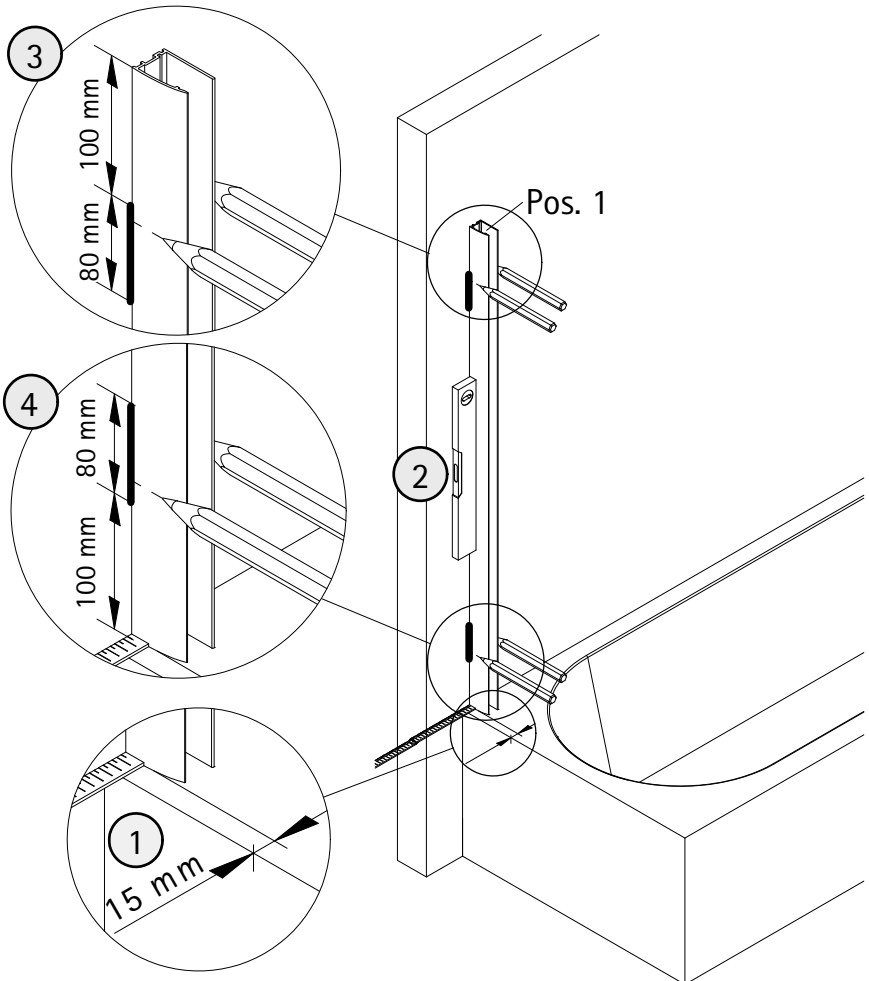

2

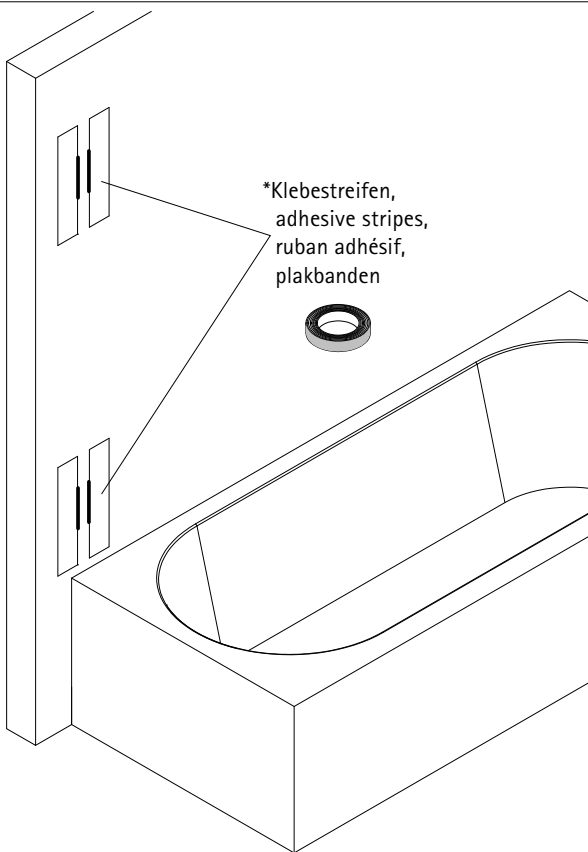

\*Klebestreifen,  
adhesive stripes,  
ruban adhésif,  
plakbanden

\* Nicht im Lieferumfang enthalten,  
not included in delivery,  
non fourni dans l'emballage,  
niet bij levering inbegrepen,

3

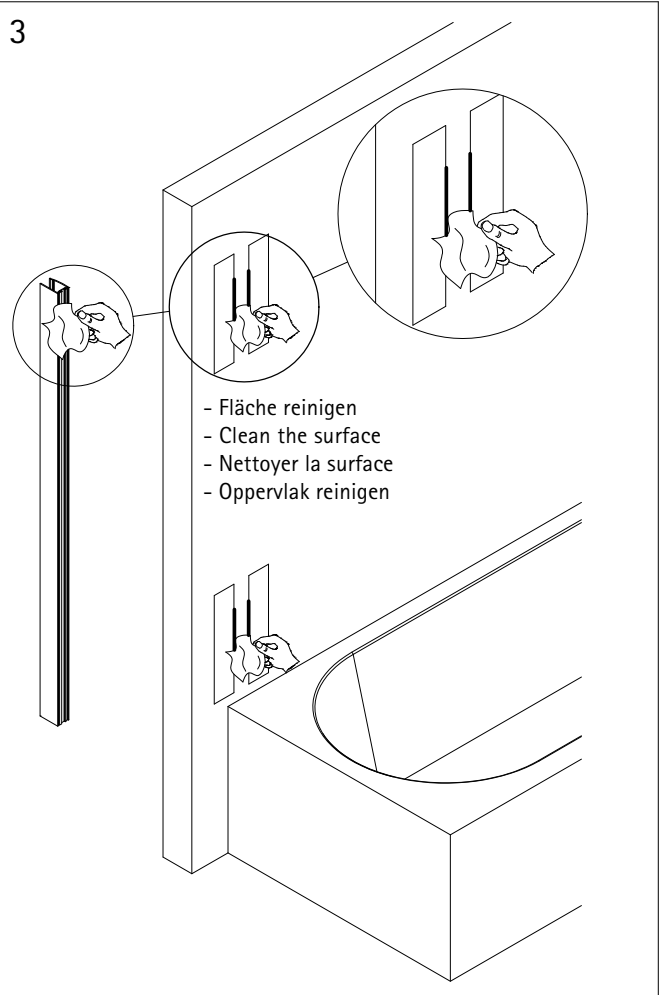

- Fläche reinigen  
- Clean the surface  
- Nettoyer la surface  
- Oppervlak reinigen

4 - Kleber nach Anleitung anrühren  
und auf die gekennzeichneten Flächen  
des Wandanschlußprofils auftragen.

- Mix glue according to the instructions  
and apply the mixture on the marked areas.
- Appliquez la colle mélangée selon les  
instructions sur la surface marquée du profilé.
- Lijm volgens voorschrift omroeren en  
op de gemarke oppervlaktes van het  
wandaansluitprofiel aanbrengen.

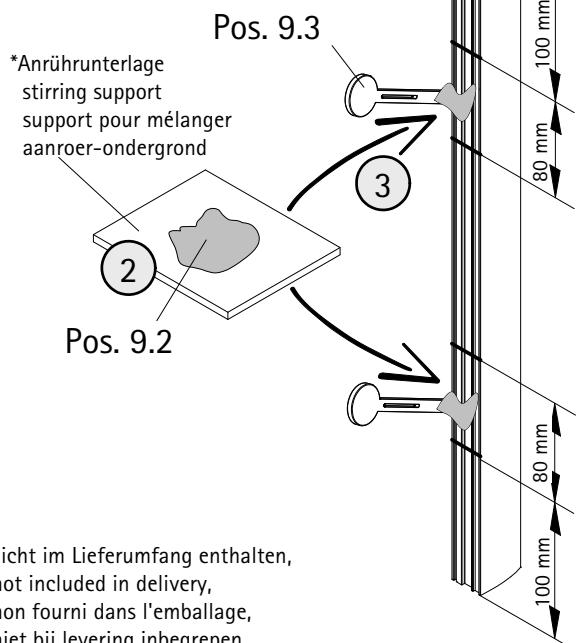

\*Anrührunterlage  
stirring support  
support pour mélanger  
aanroer-ondergrond

Pos. 9.2

Pos. 9.3

\* Nicht im Lieferumfang enthalten,  
not included in delivery,  
non fourni dans l'emballage,  
niet bij levering inbegrepen,

5

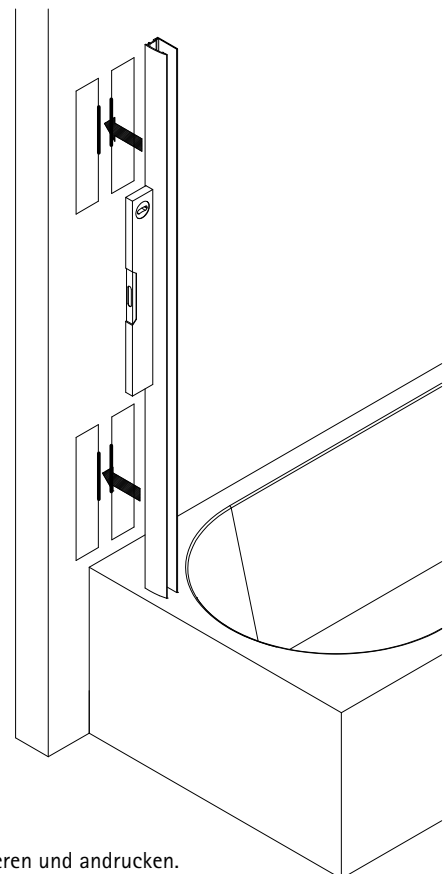

- Profil positionieren und andrücken.
- Position profile and press it onto the wall.
- Positionnez le profilé et appuyez le fortement contre le mur.
- Profiel plaatsen en aandrukken.

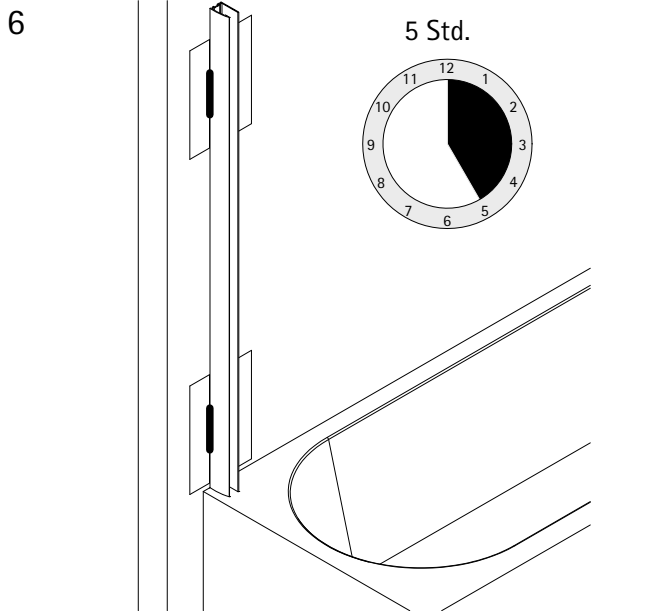

- Nach ca. 5 Stunden kann die Montage der Badewannenfaltwand begonnen werden.
- After approx. 5 hours the bath screen can be installed.
- Après env. 5 heures le montage du pare-baignoire peut démarrer.
- Na 5 uur kan met de montage van de badwand worden gestart.

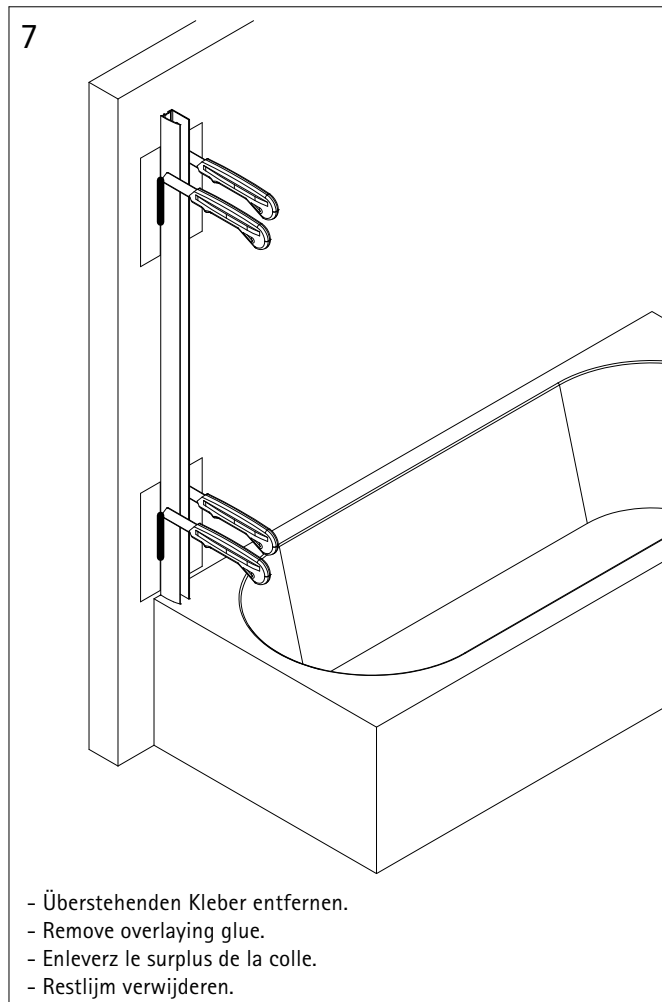

- Überstehenden Kleber entfernen.
- Remove overlying glue.
- Enlevez le surplus de la colle.
- Restlijm verwijderen.

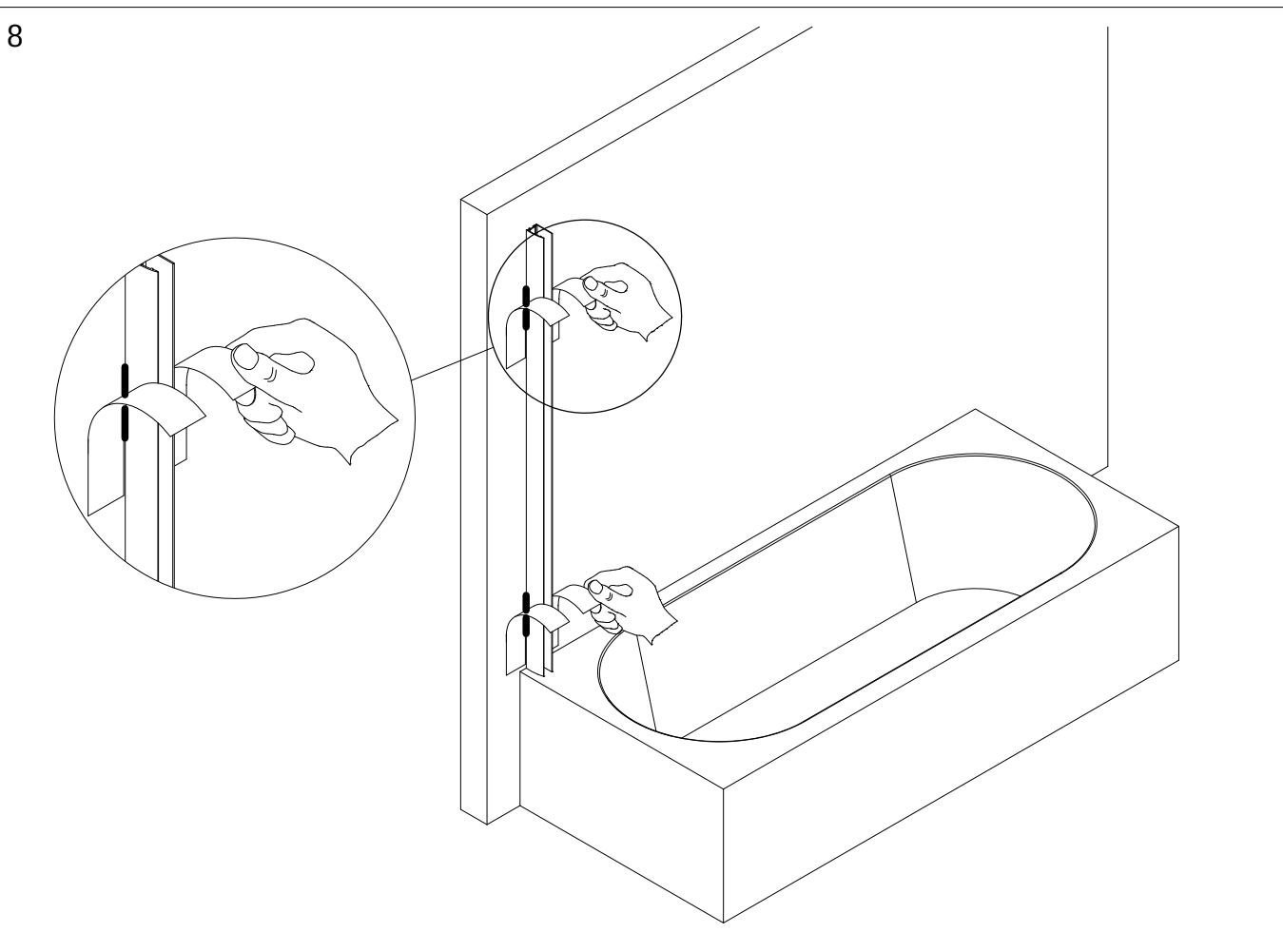



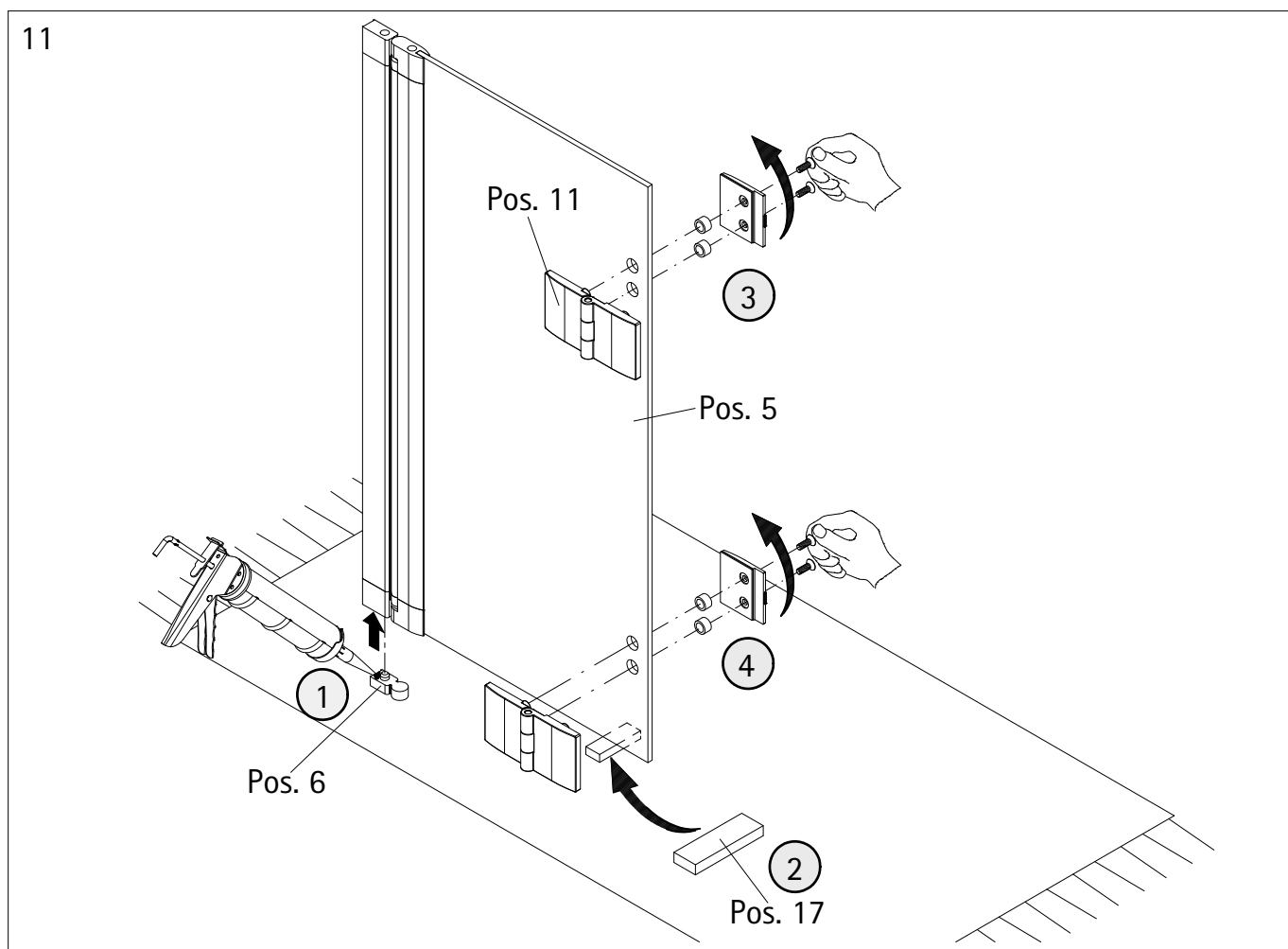
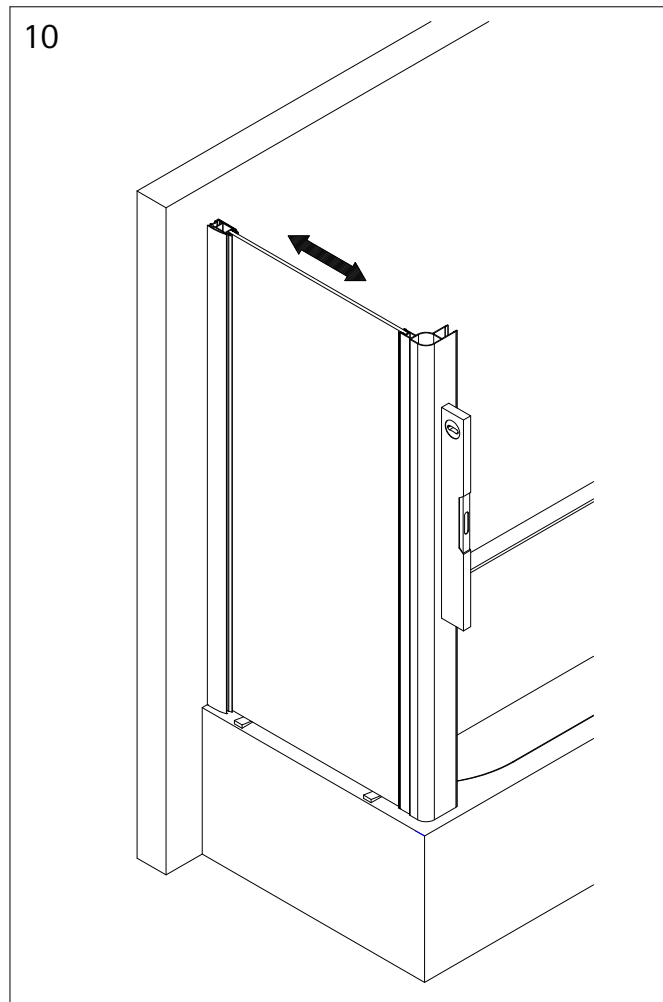
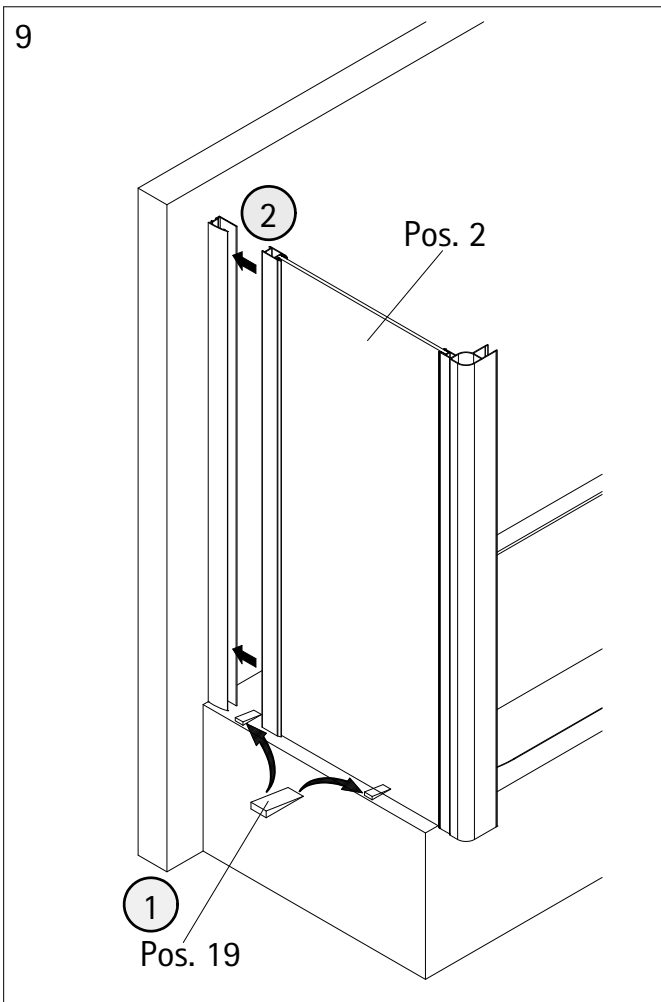

12

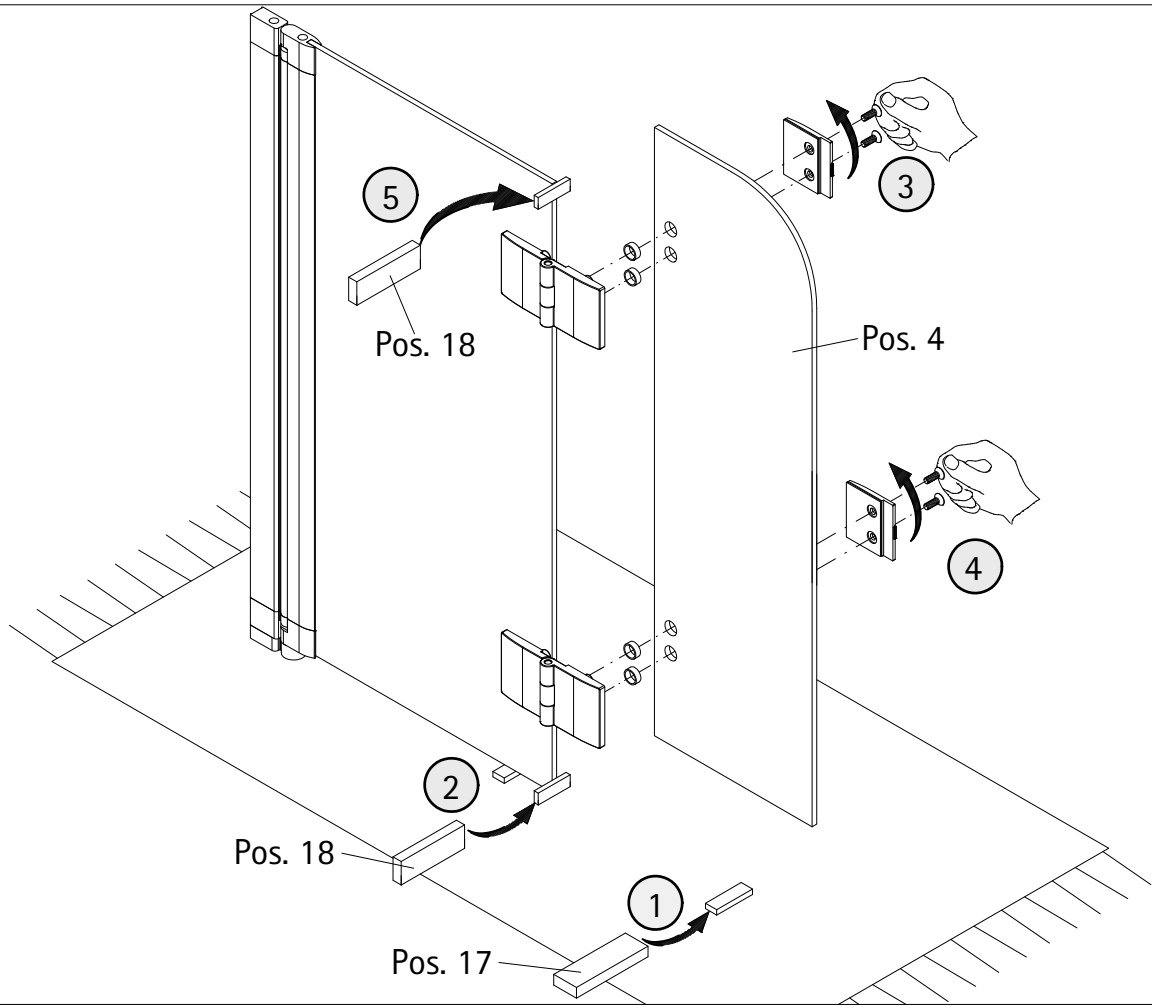

13

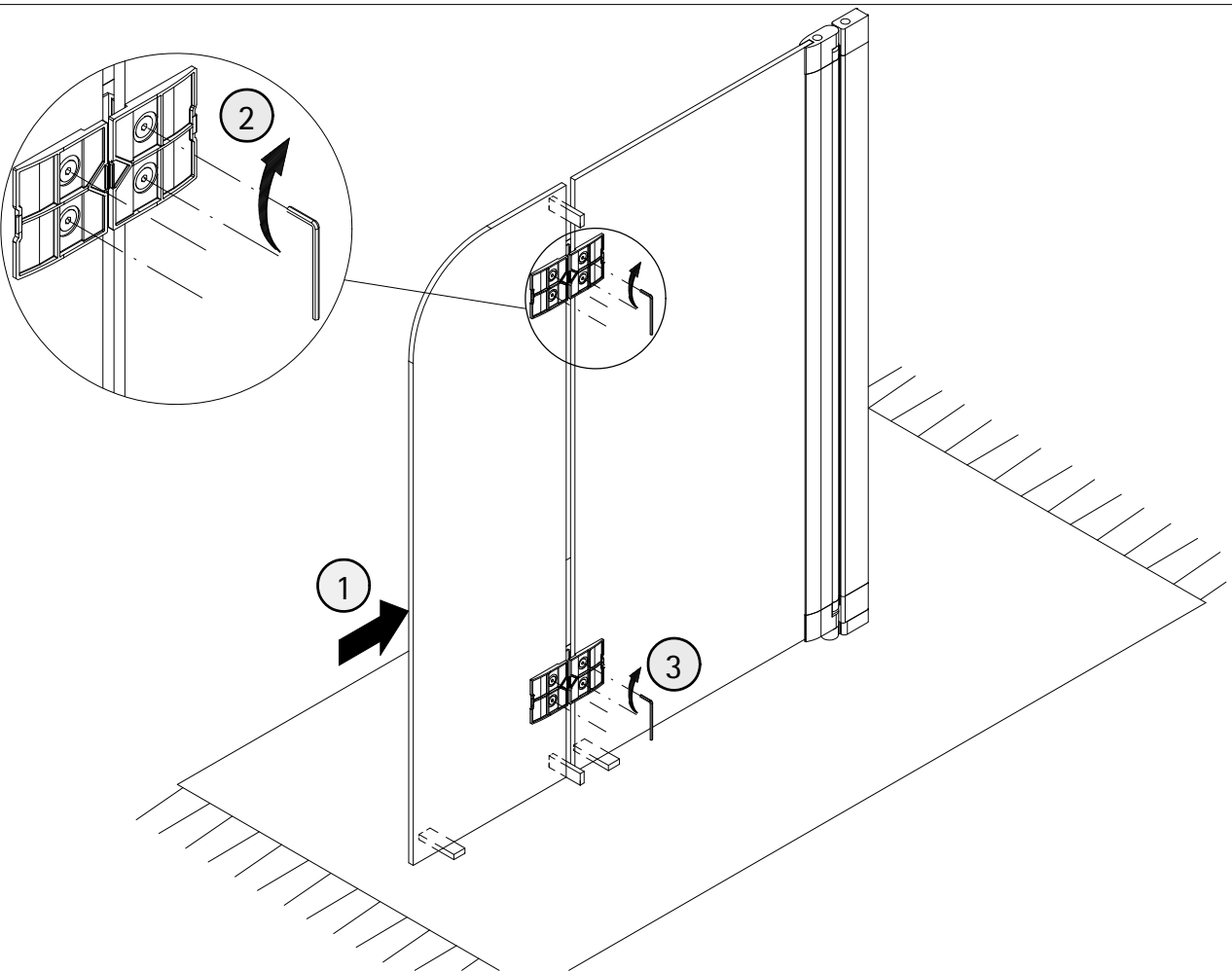

14

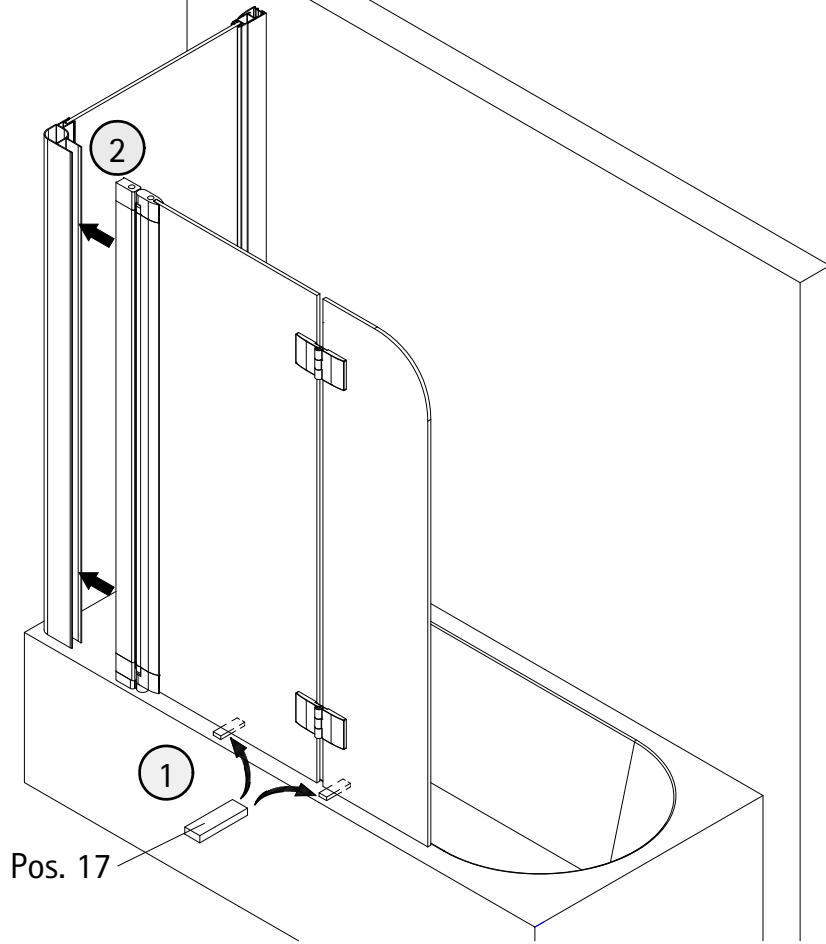

15

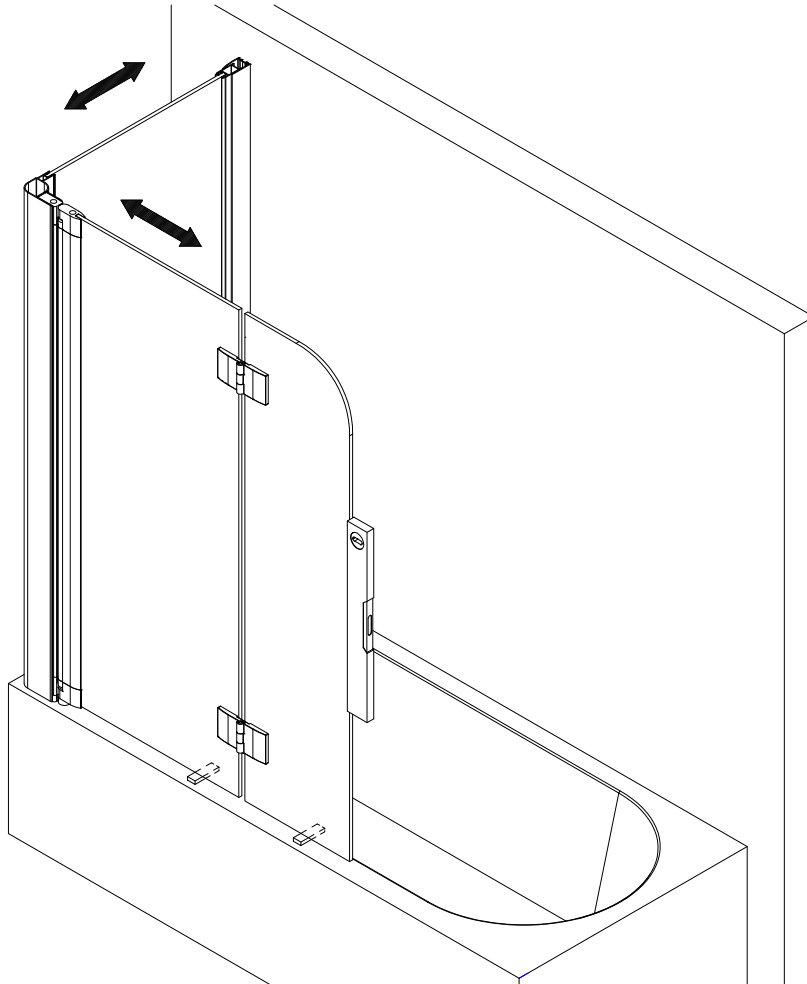

16

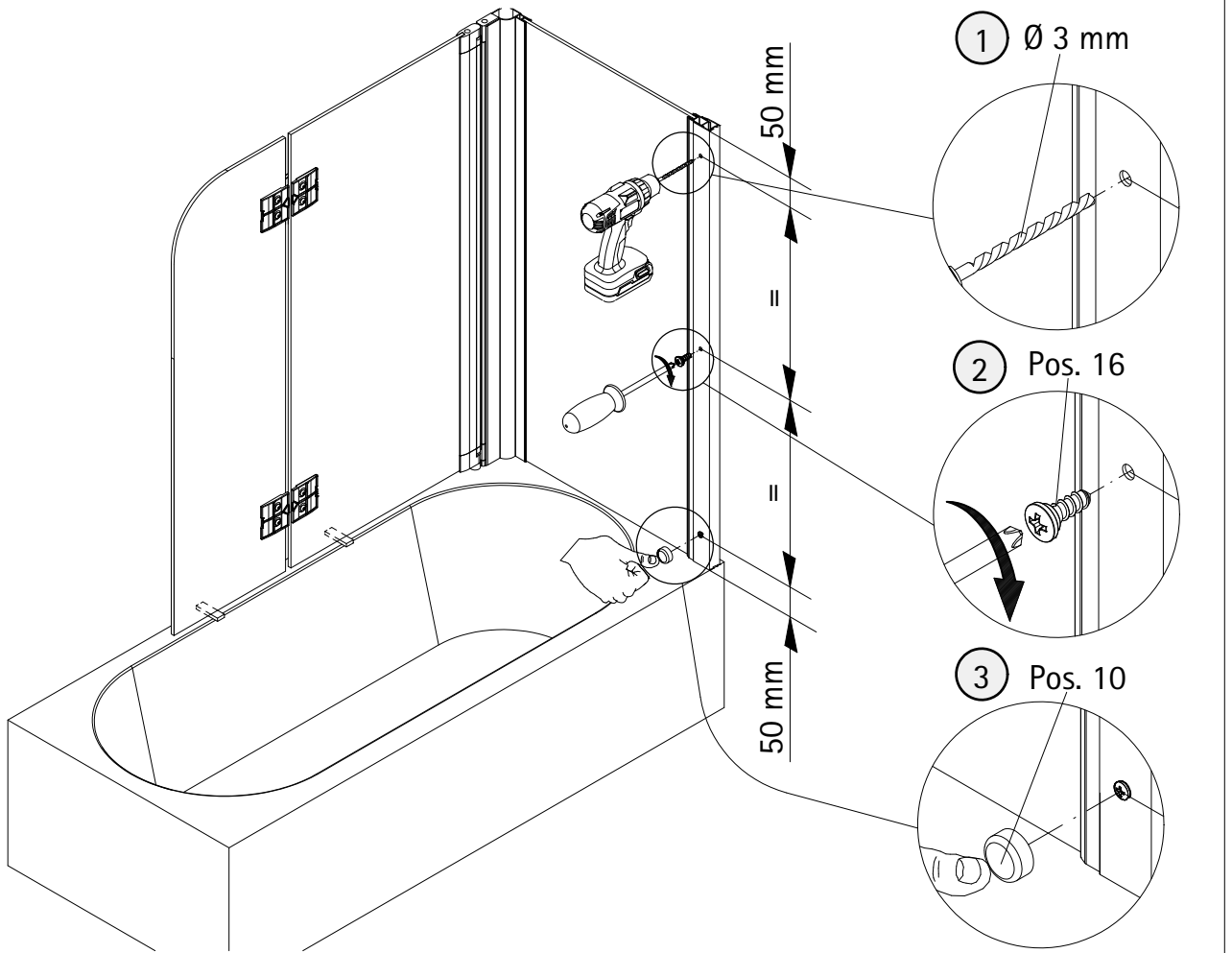

17

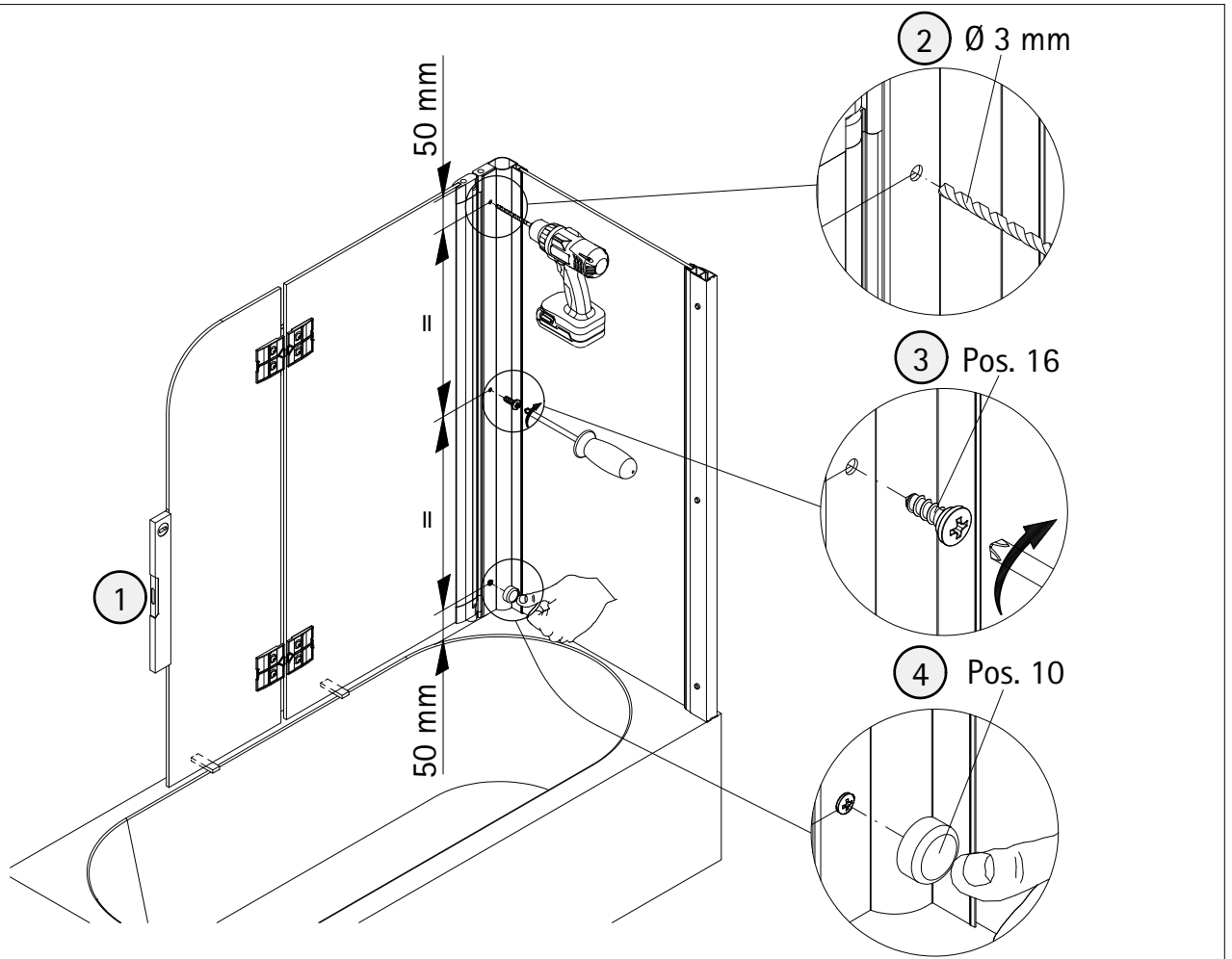

18

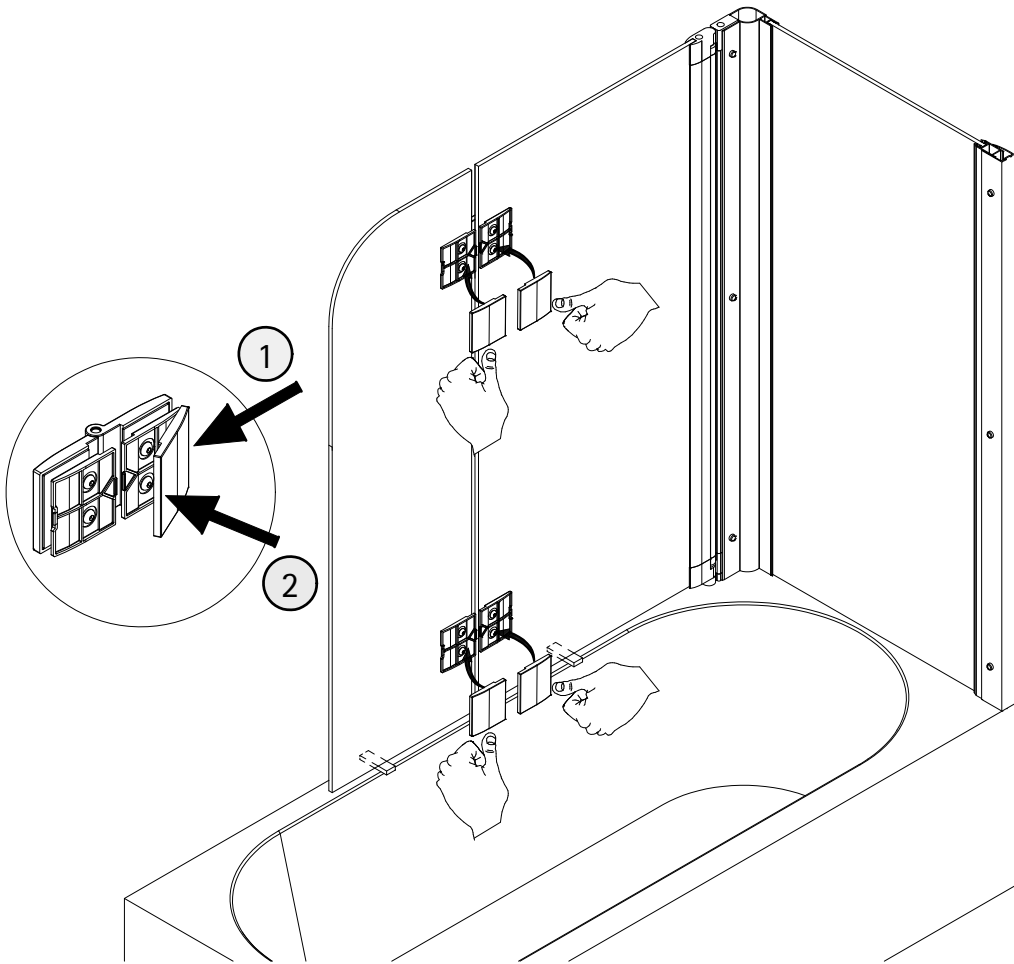

19



- Beipackzettel unbedingt beachten.
- Note: Read enclosed instruction leaflet carefully
- Veuillez impérativement faire attention à la notice explicative.
- Let op: les de bijsluiter

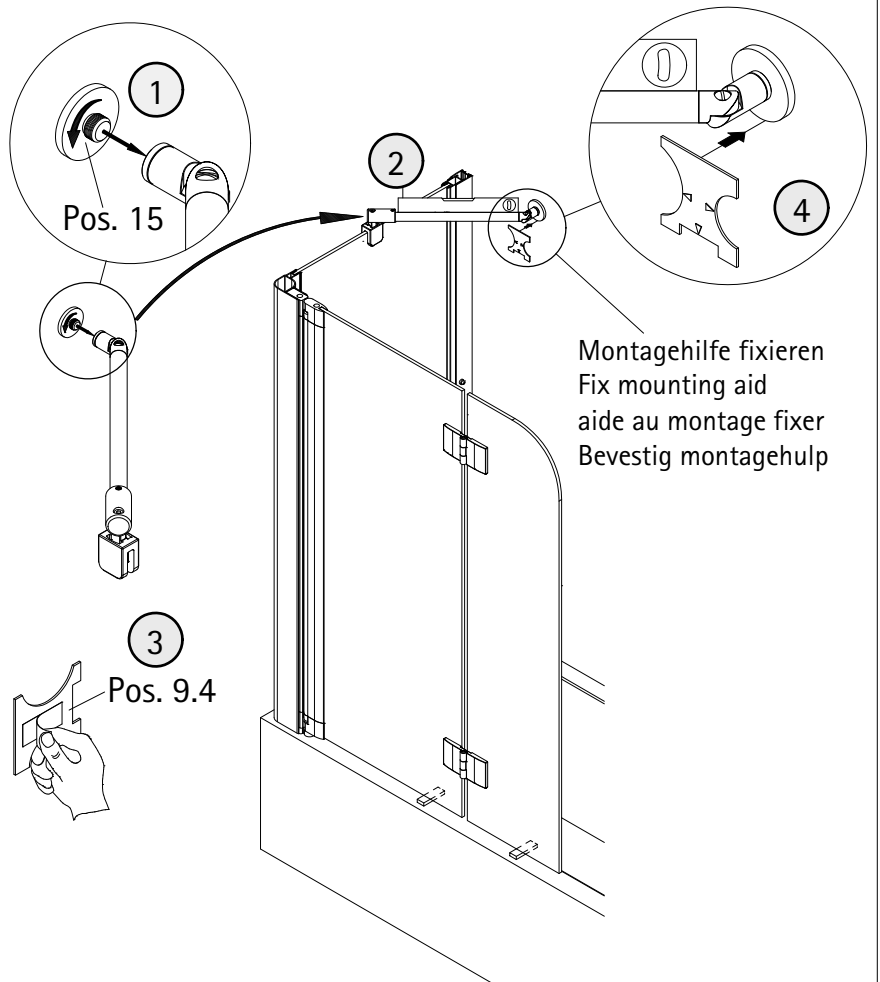

20

- Oberfläche reinigen
- Clean the surface
- Nettoyer la surface
- Oppervlak reinigen

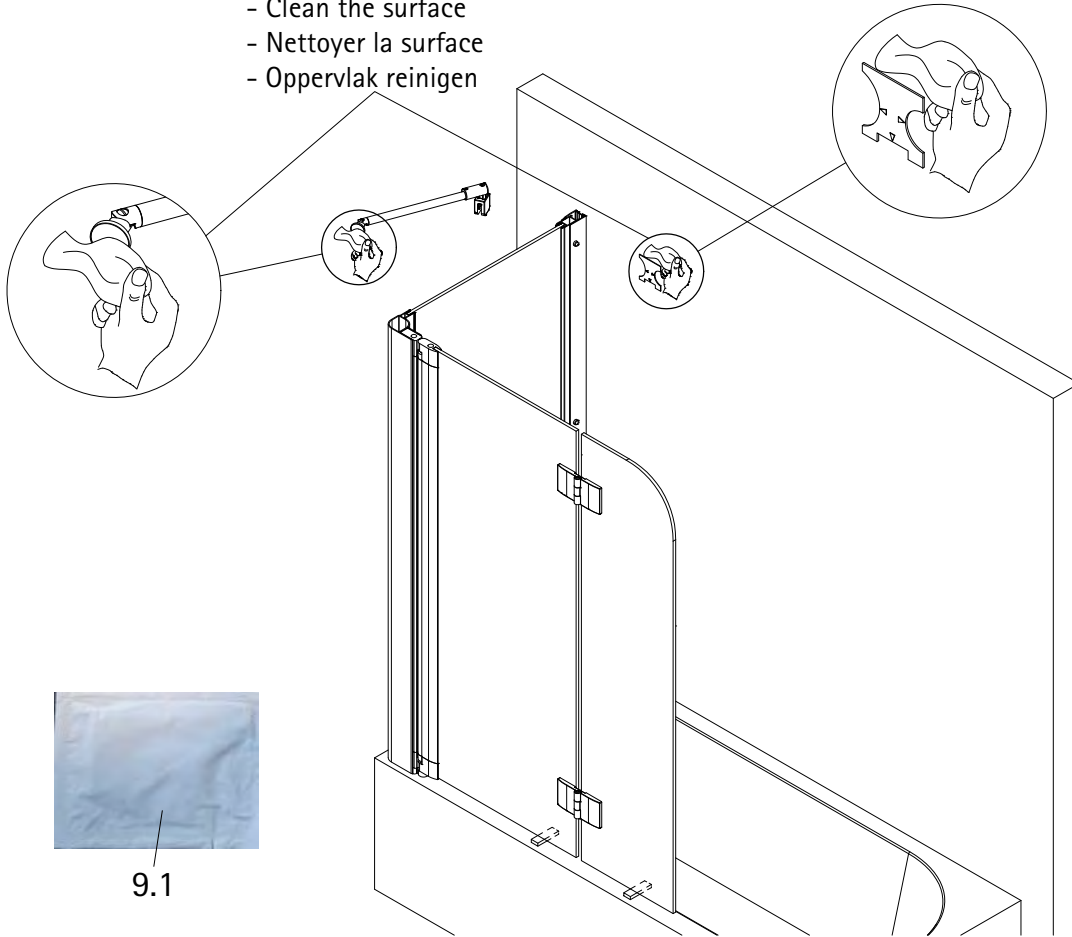

21

- Kleber nach Anleitung anrühren und auf die gekennzeichnete Fläche des Stabilisationsbügels auftragen.
- Mix glue according to the instructions and apply the mixture on the marked areas.
- Appliquez la colle mélangée selon les instructions sur la surface de la barre de stabilisation.
- Lijm volgens voorschrift omroeren en op de gemerkte oppervlaktes van het stabilisatie stang aanbrengen.

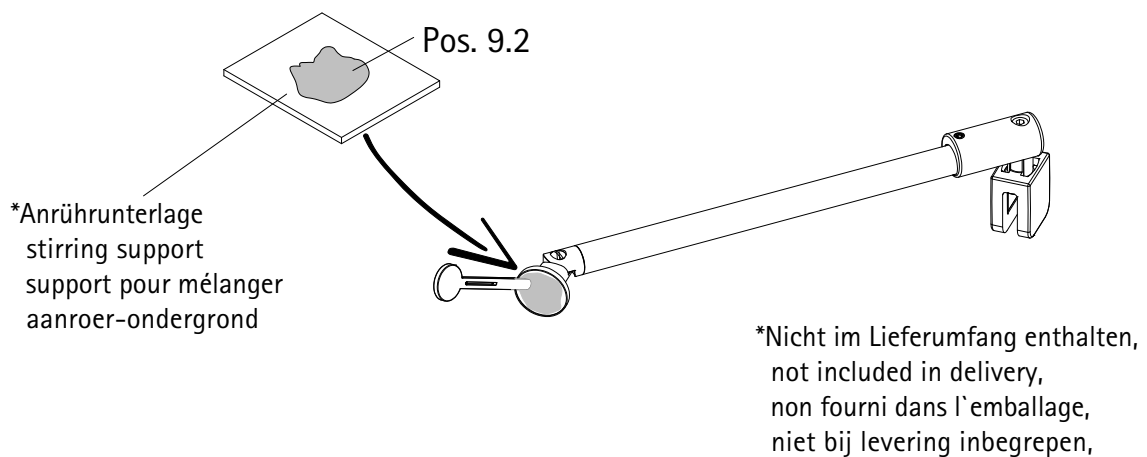

22

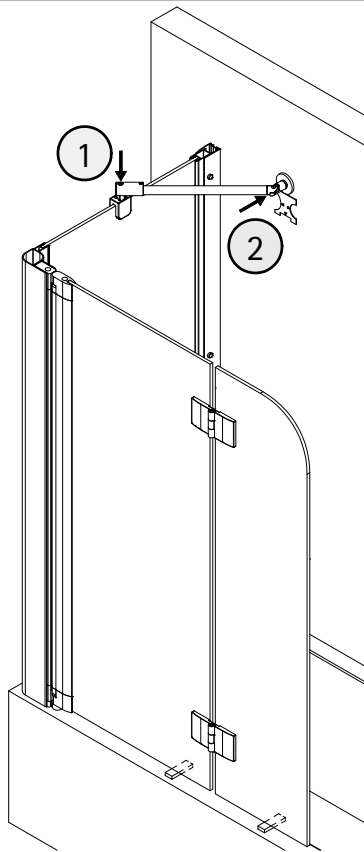

- positionieren und andrücken.
- Position press in onto the wall.
- Positionnez et appuyez le fortement contre le mur.
- plaatsen en aandrukken.

3

5 Std.

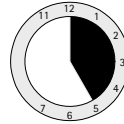

- Nach 5 Stunden kann die Montage fortgesetzt werden.
- After approx 5 the installation process can be continued.
- Après 5 heures le montage peut continuer.
- Na 5 uur kan met de montage worden verfolgd.

23

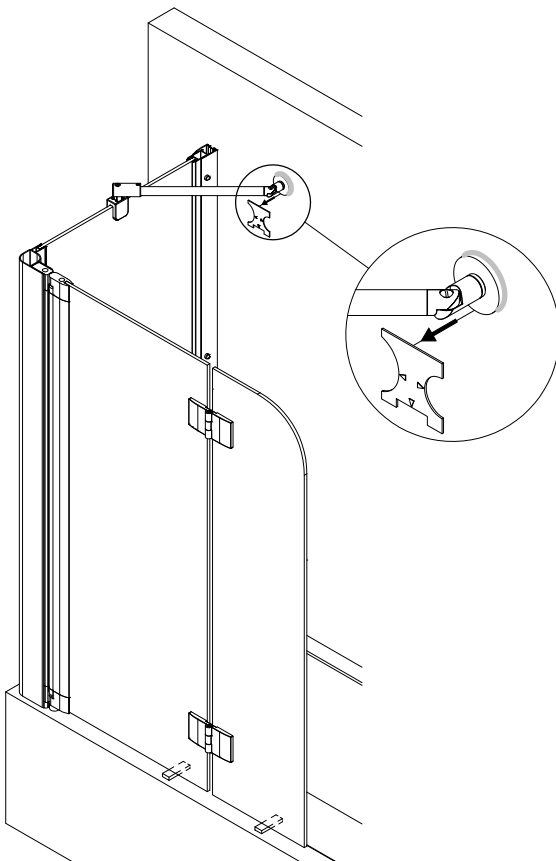

24

- Überstehenden Kleber entfernen.
- Remove overlaying glue.
- Enlevez le surplus de la colle.
- Restlijm verwijderen.

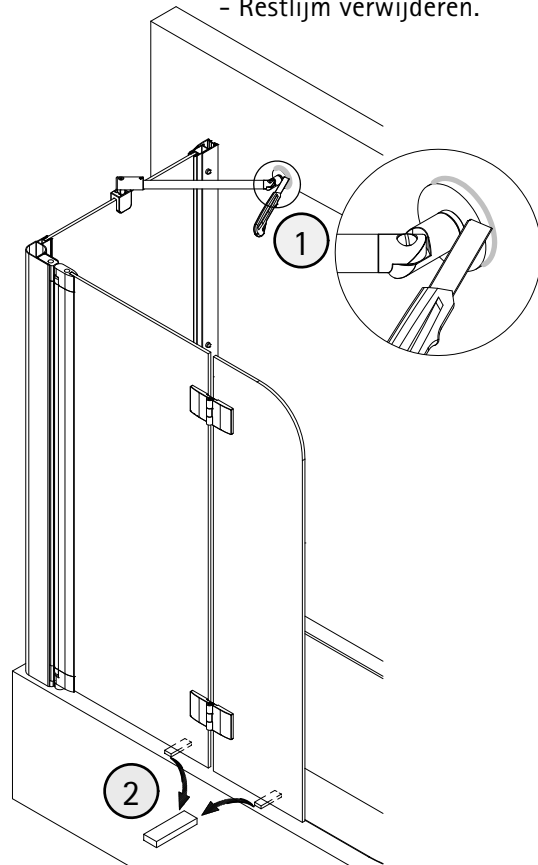

25

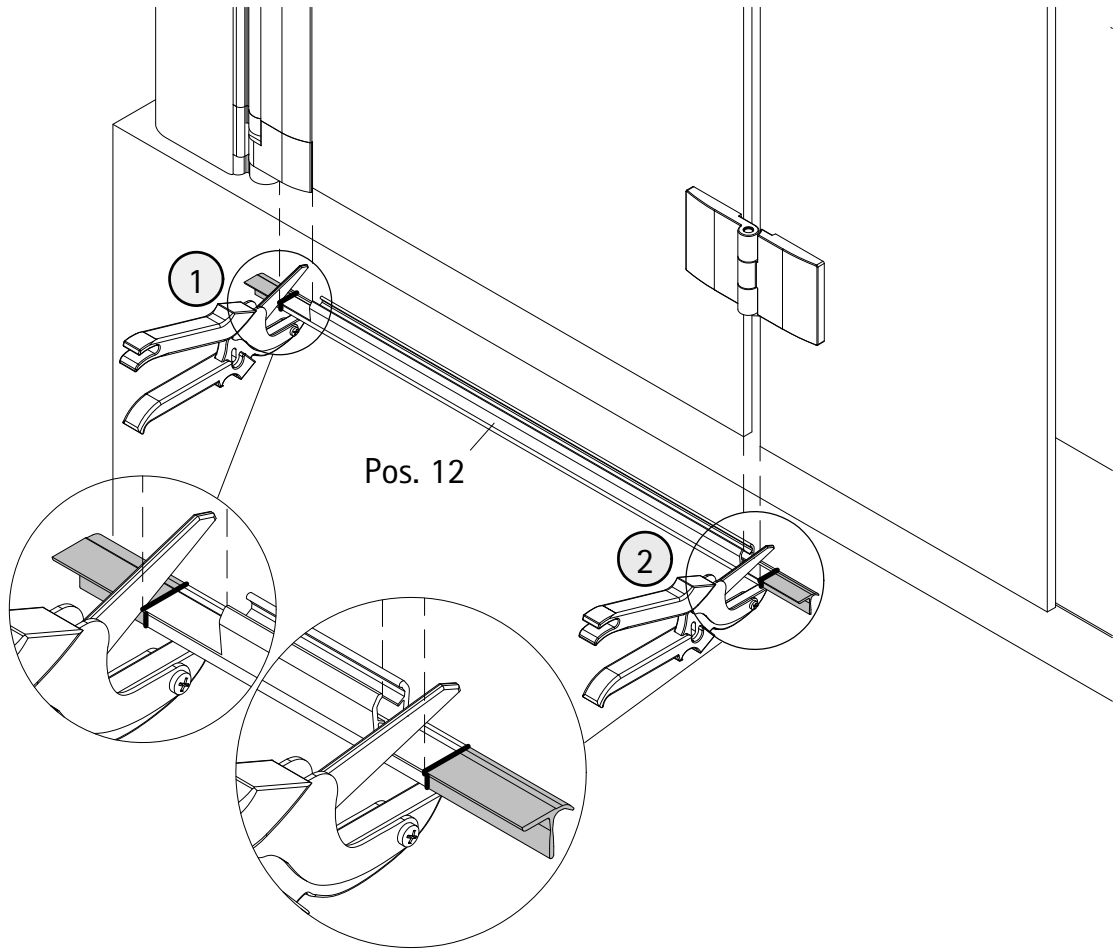

26

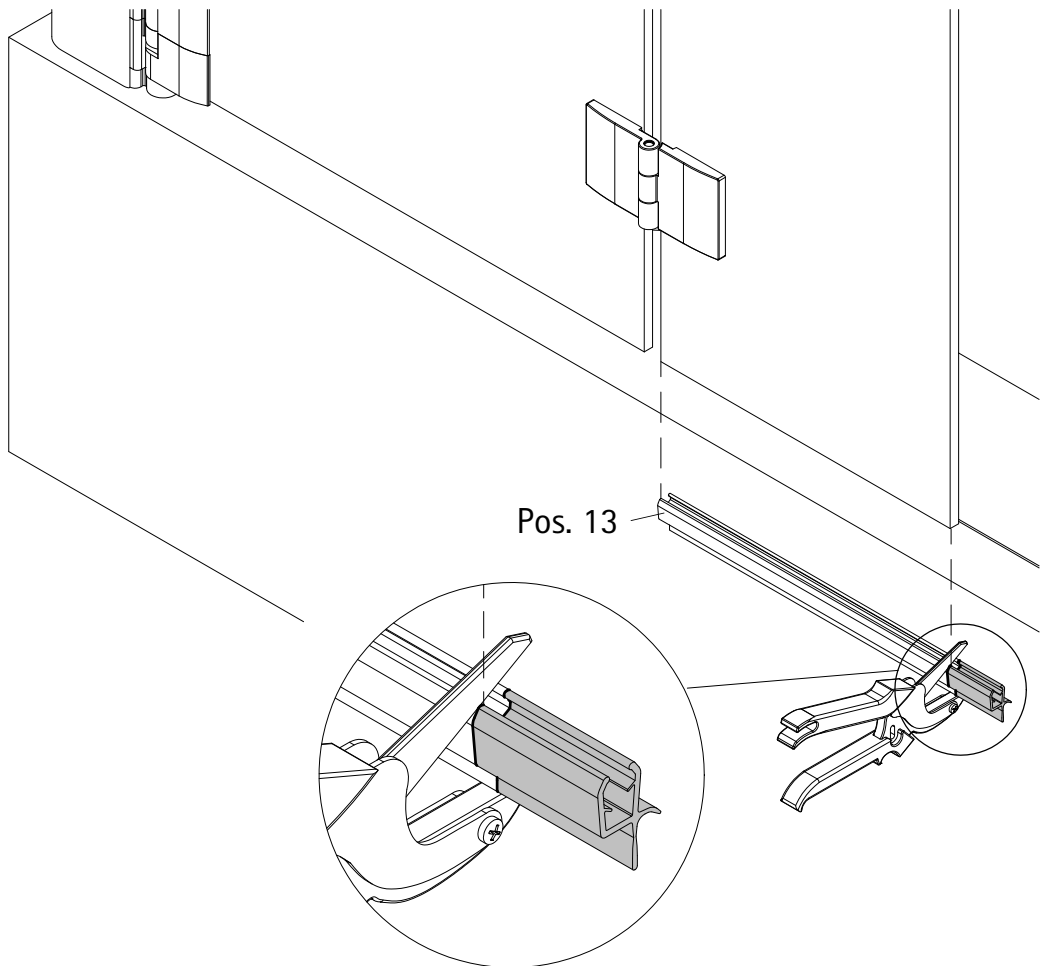



27

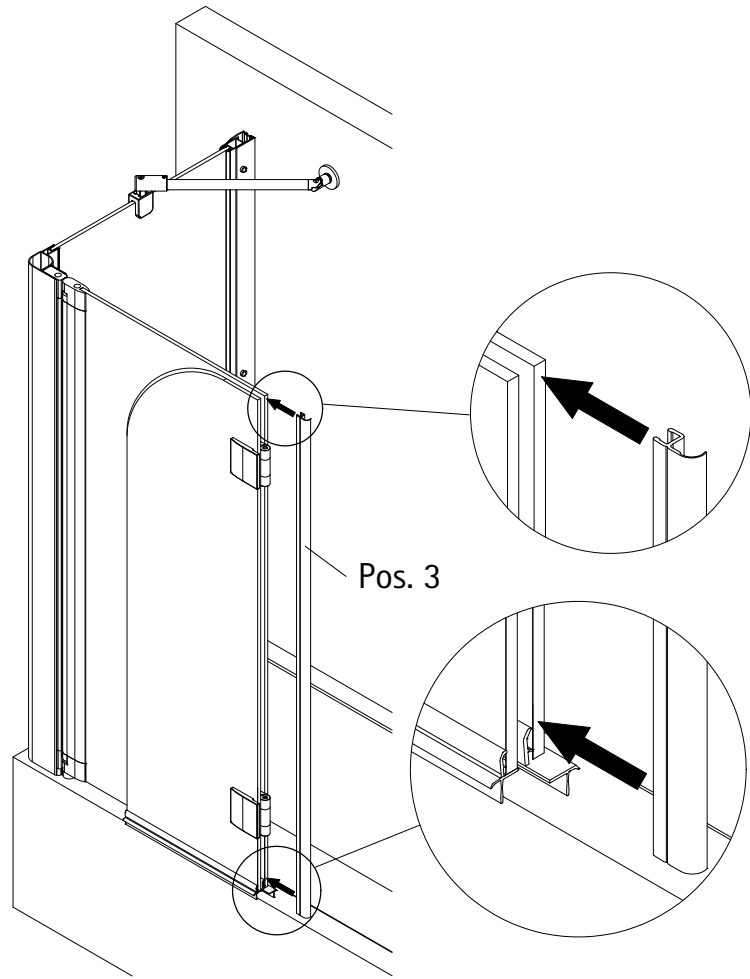

28

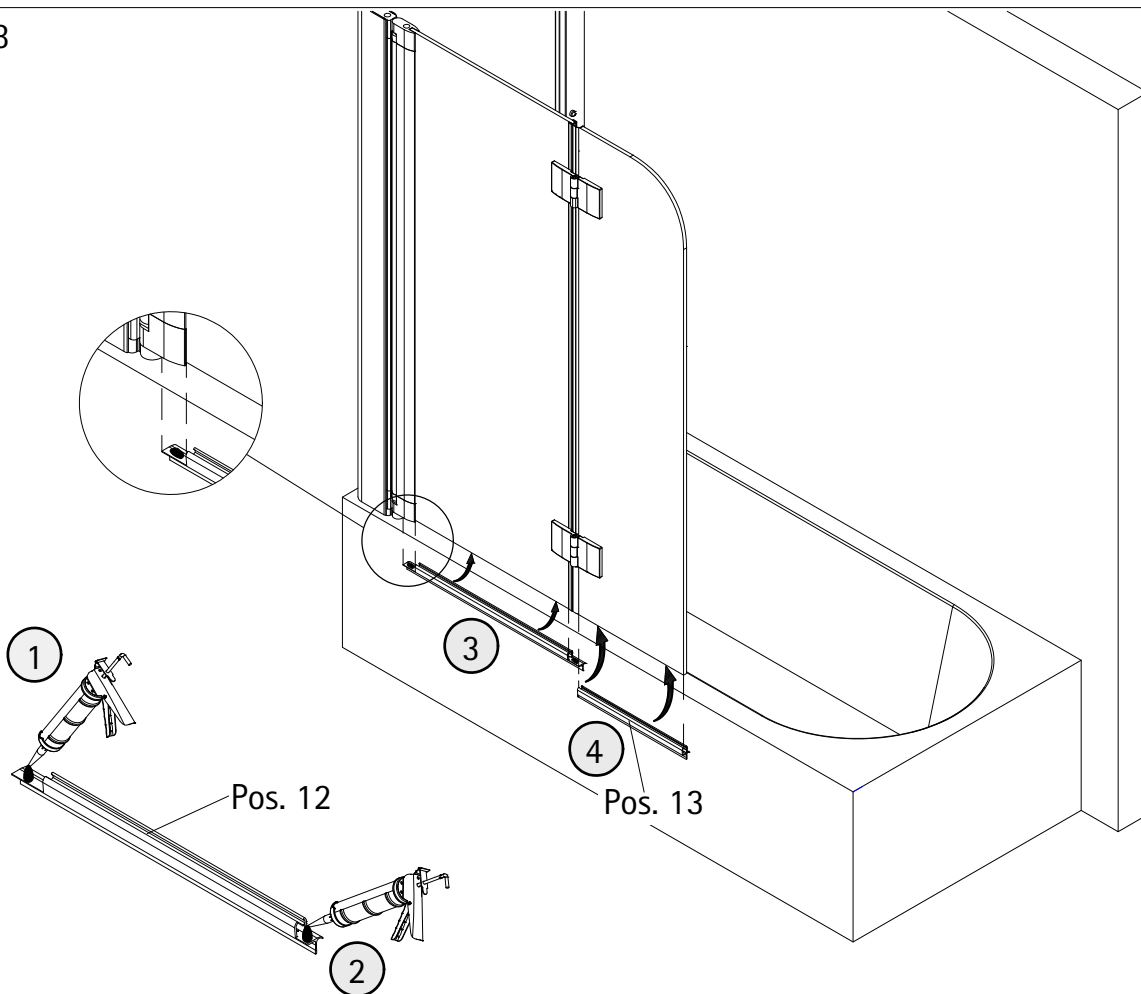

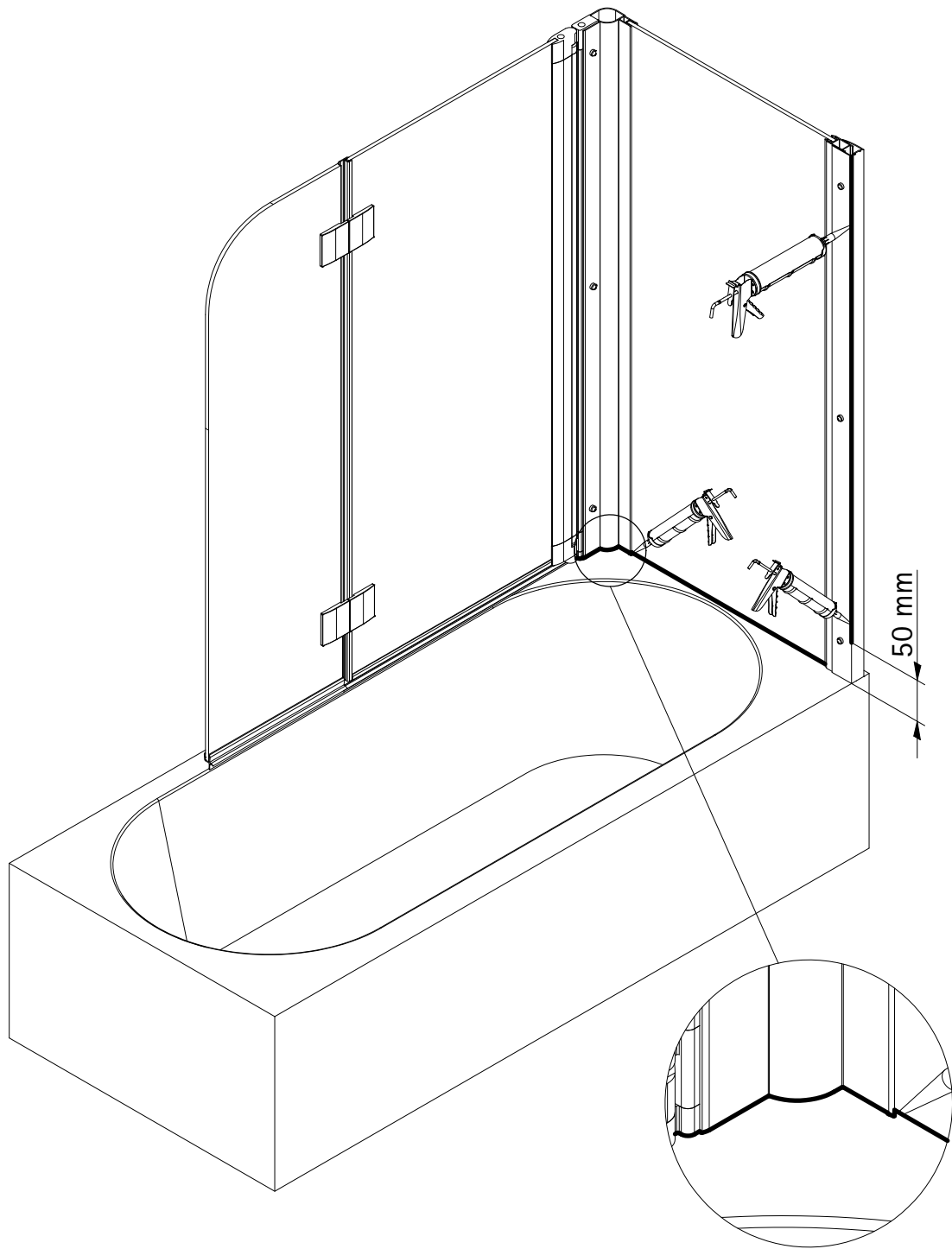

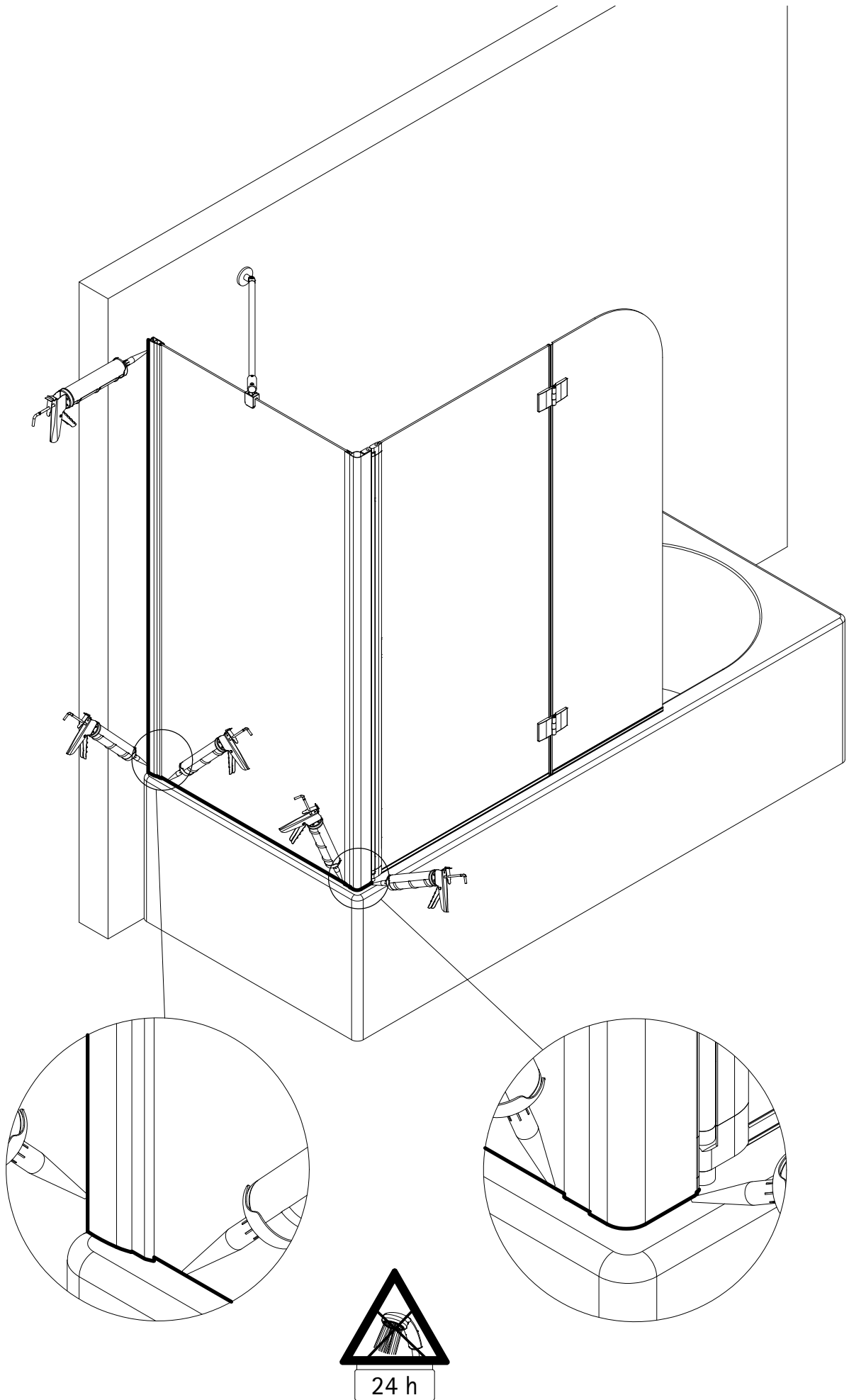

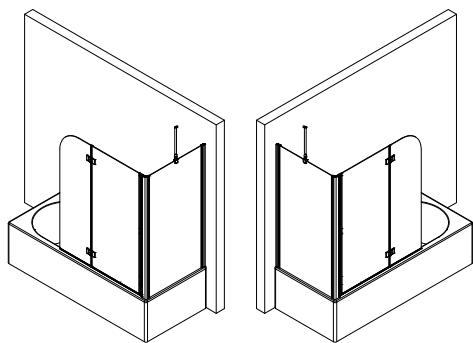

Prüfnummer / Inspection number / Numéro d'essai / Testnummer



Ersatzteilbestellung / spare parts order  
commande de pièces de rechange / Bestelling van reserveonderdelen:  
Fax 02962 / 972-4260



Technische Hilfe / technical help / l'aide technique / technologische ondersteuning  
Telefon 02962 / 972-40



E-Mail:  
[ersatzteile@duschservice.de](mailto:ersatzteile@duschservice.de)



Duschservice  
Zum Hohlen Morgen 22  
59939 Olsberg  
Deutschland / Germany / Allemagne / Duitsland



0000735160000000000000000000