

4112-8  
03-23

## - Montageanleitung -

(bitte zusammen mit dem Kaufbeleg aufbewahren)

---

D967504 / D967541

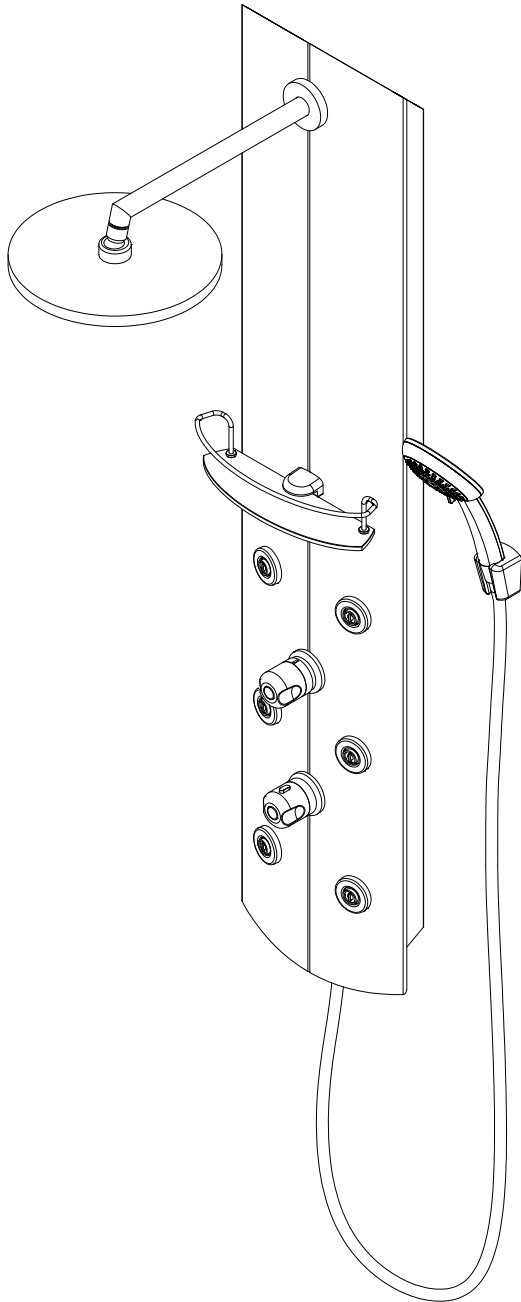

D967604 / D967641

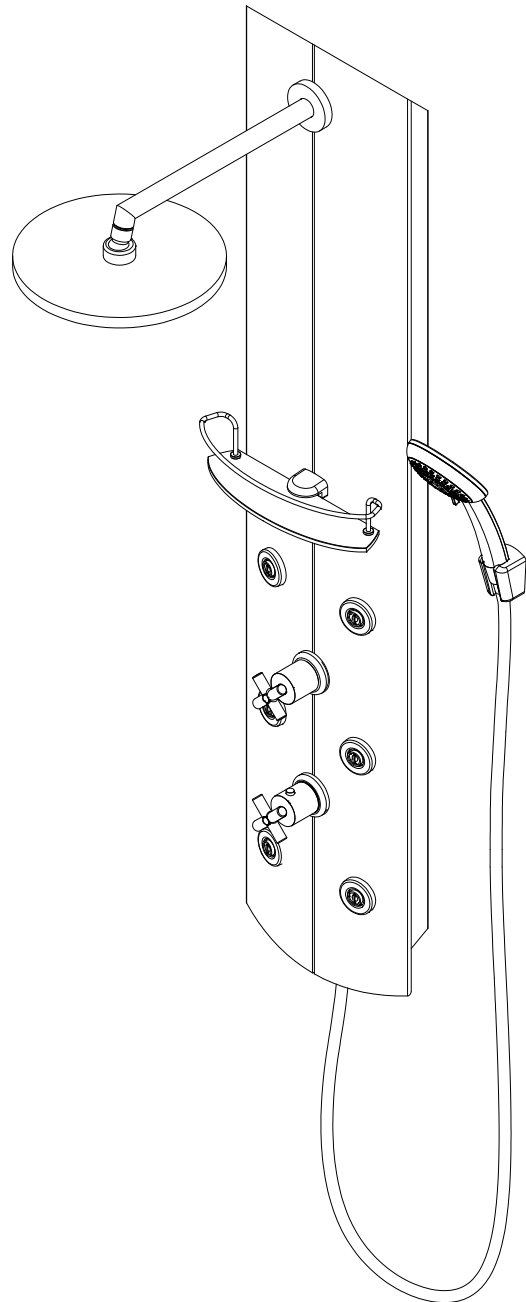

---

- Assembly instructions -

(please retain and file together with the purchase receipt)

- Notice de montage -

(à conserver et à accrocher impérativement avec le justificatif d'achat)

- Montagehandleiding -

(samen met de aankoopfactuur in ieder geval bewaren)

Maßzeichnung, dimensional drawing, dimensions, maatekening

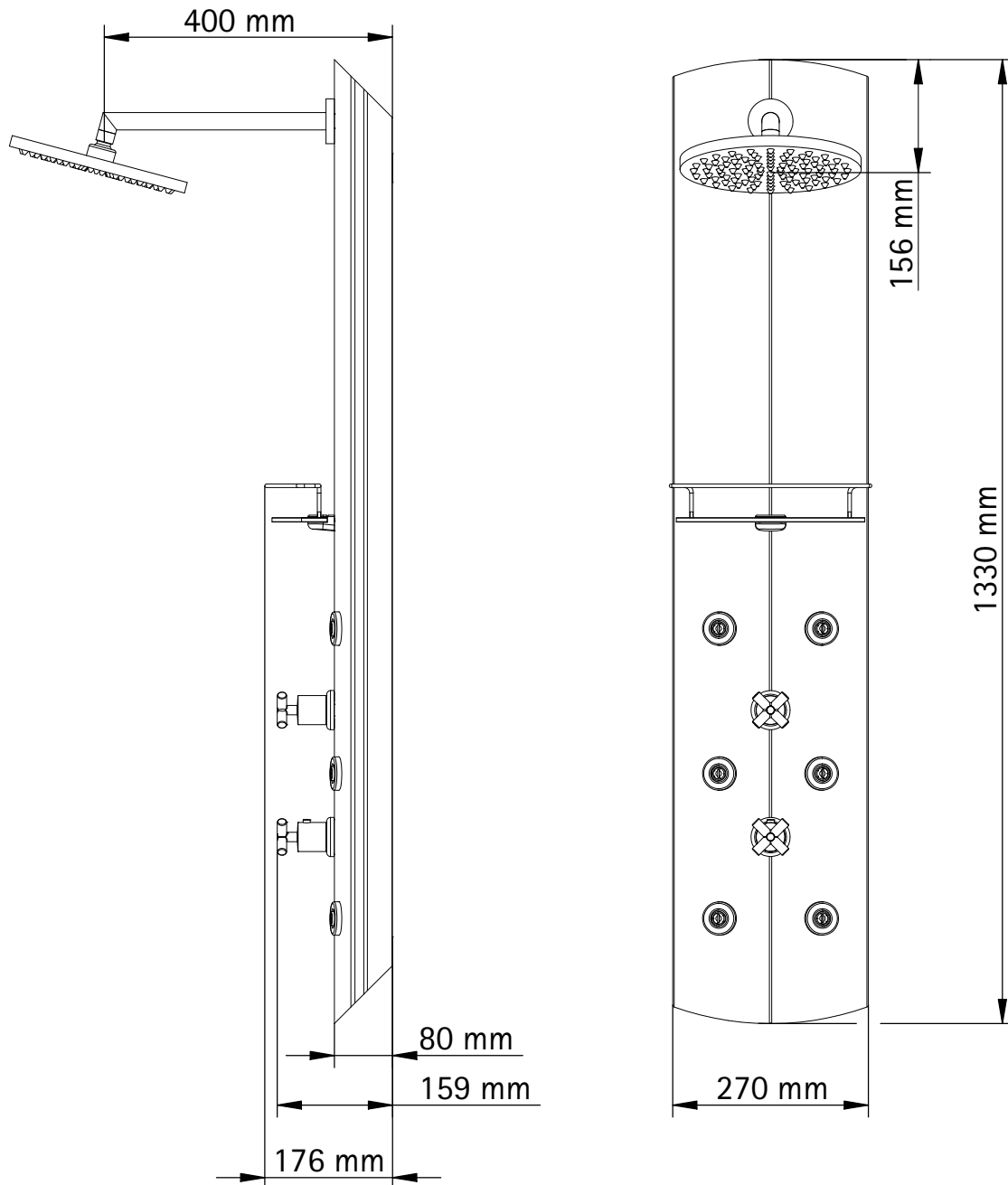

**Info**

- de** Alle Maßangaben unterliegen einer Toleranz von  $\pm 5$  mm
- en** All dimensions are subject to a tolerance of  $\pm 5$  mm
- fr** Toutes les mesures sont soumises à une tolérance de  $\pm 5$  mm
- nl** Alle maten hebben een tolerantie van  $\pm 5$  mm

# Ersatzteilübersicht, spare parts overview, aperçu des pièces détachées, onderdelen overzicht

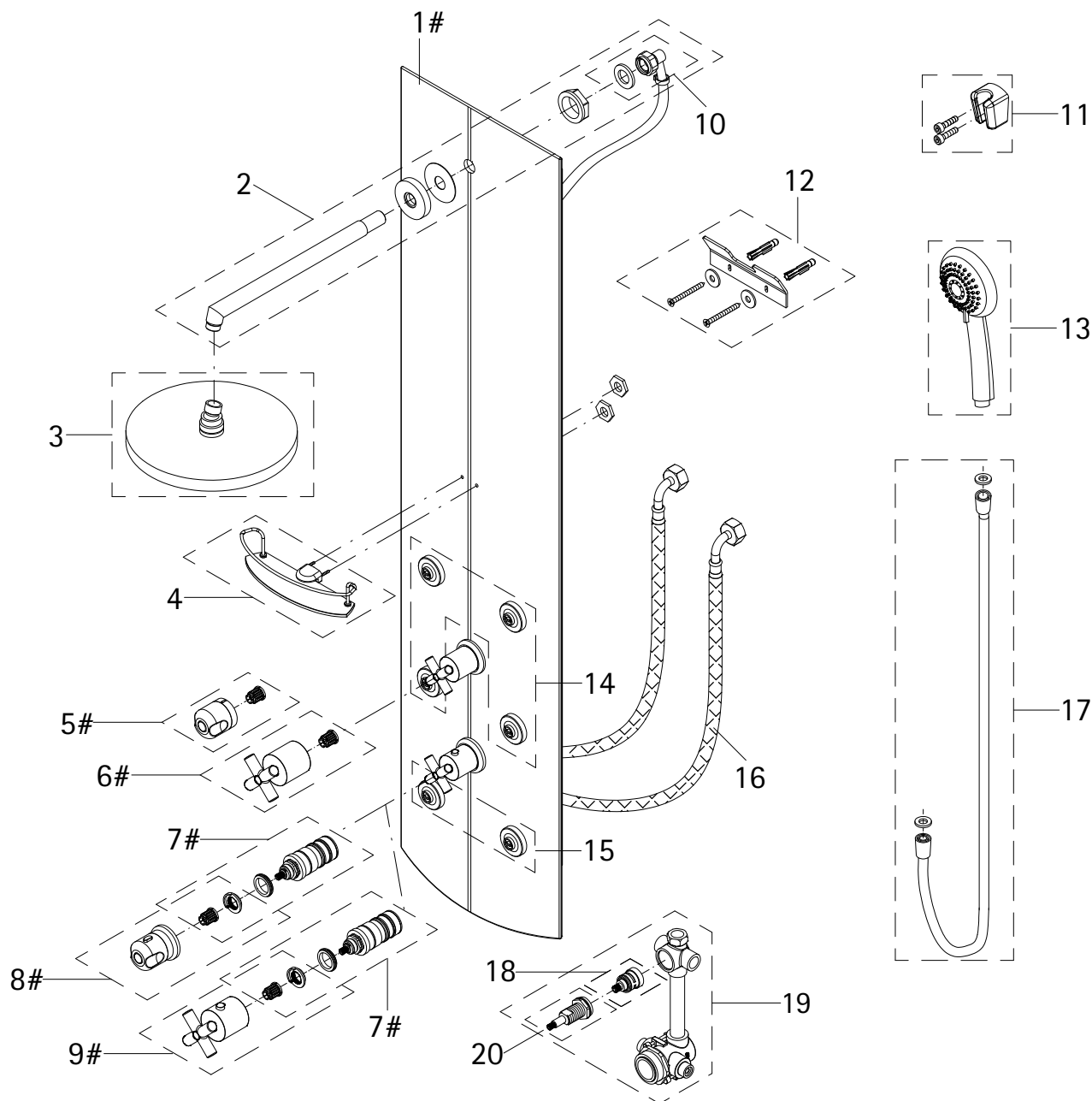

## # optional wählbar

**Info**

**de** Bei der Ersatzteilbestellung bitte unbedingt die entsprechende Artikelnummer vom Kaufbeleg angeben.  
**en** When ordering spare parts, please specify the item on the order form.

**fr**

Lors de la commande des pièces détachées veuillez donner le numéro d'article conforme au bon d'achat.  
**nl** Bij een onderdeel bestelling het juiste artikelnummer overnemen vanaf het aankoopbewijs.

Pos.	Bezeichnung	Ersatzteil-Nr.	Preis	Pos.	Bezeichnung	Ersatzteil-Nr.	Preis
1.1#	1x Duschpaneel (Alu-Chromoptik)	E 98534-41	Stück 396,00 €	11	1x Handbrausehalter (Chromoptik)	E98522-1-41	Stück 20,95 €
1.2#	1x Duschpaneel (Alu-WeiBoptik)	E 98534-04	Stück 396,00 €	12	1x Aufhängeprofil	E98579-1	Stück 24,95 €
2	1x Blende Rohr zur Kopfbrause	E98505-41	Stück 76,00 €	13	1x Handbrause (Chromoptik)	E98520-29-41	Stück 26,95 €
3	1x Kopfbrause, rund Ø 250 mm x 15 mm, (Chromoptik)	E98521-28-41	Stück 59,95 €	14	4x Massagedüse, komplett (Chromoptik)	E98525-1-41	Stück 54,95 €
4	1x Ablage komplett	E 98518-2	Stück 66,95 €	15	2x Massagedüse, komplett (Chromoptik)	E98525-2-41	Stück 54,95 €
5#	1x Griff Absperrventil (Chromoptik)	E98554-13-41	Stück 66,00 €	16	2x Anschlußschläuche	E98517	Set 74,95 €
6#	1x Kreuzgriff Absperrventil (Chromoptik)	E98554-4-41	Stück 66,00 €	17	1x Brauseschlauch 1,5 m (Chromoptik)	E98515-6-41	Stück 24,95 €
7#	1x Thermostatkartusche	E98541-KT1-3	Stück 106,00 €	18	1x Kartusche 3-Wege Umsteller	E98547-KT22	Stück 66,00 €
7.1#	1x Thermostatkartusche	E98541-KT1-1	Stück 106,00 €	19	1x Adapterstück zur Kartusche	E98588	Stück 64,00 €
8#	1x Griff Thermostatkartusche (Chromoptik)	E98560-18-41	Stück 62,00 €	20	1x Armaturenblock	E98547-1	Stück 205,00 €
9#	1x Kreuzgriff Thermostatkartusche (Chromoptik)	E98560-8-41	Stück 62,00 €				
10	1x Drehbares Eckstück	E98529	Stück 20,95 €		# Montagezubehör	E98500	Set 38,95 €

# Info

**de** Anschlussmaße Duschpaneele **fr** Dimensions de raccordement des panneaux de douche

**en** Connection dimensions **nl** Aansluiting douchepanelen

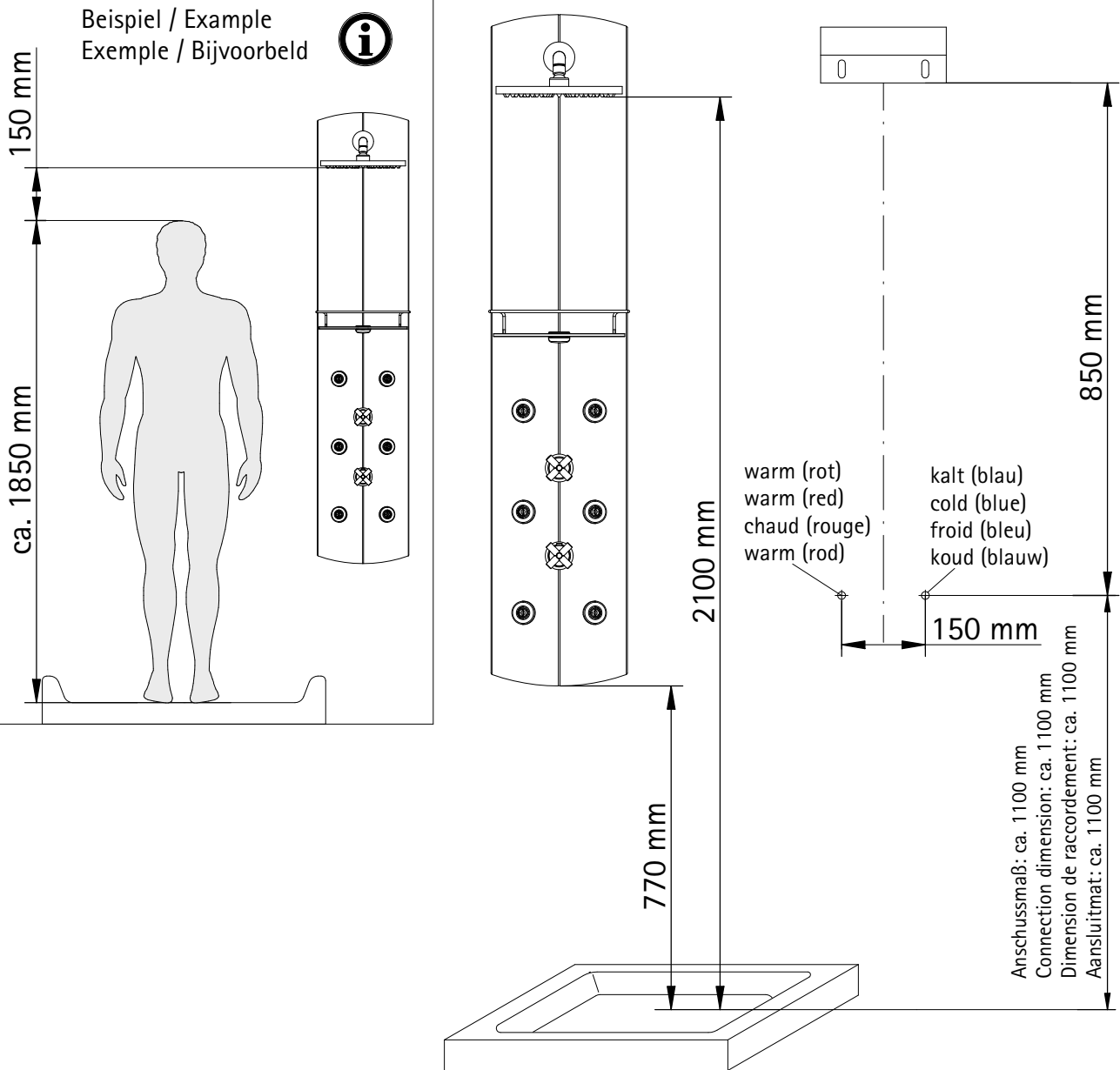

**de**

Anschlussmaße nicht bindend, da flexible Schläuche Variationsmöglichkeiten.

Faustformel: Unterkante Kopfbrause = Körpergröße + 15 cm.  
Hinweis: Idealerweise sollte die Höhe der Duschpaneele an die Körpergröße des Kunden angepasst werden, indem durch Anhalten die optimale Position ausprobiert und angezeichnet wird. Dabei ist darauf zu achten, dass keine Schläuche geknickt bzw. gequetscht werden. Das Duschpaneel muss beim Anhalten angeschlossen sein, um eventuelle Kollisionen erkennen zu können.

**en**

Connection dimensions are not fixed since flexible hoses allow for variation.  
Rule of thumb: Lower edge of the head shower = body height + 15 cm.  
Note: ideally the height of the Duschpaneele should be adjusted to the height of the customer by holding it in place and trying and marking the optimum position. In so doing, care should be taken that no hoses are kinked or crushed. When holding it in place, the Duschpaneele must be connected in order to detect any problems.

**fr**

Dimensions de raccordement sans engagement de notre part car les tuyaux flexibles sont sujets à des possibilités de variation.  
Règle approximative: bordure inférieure de douchette de tête = taille corporelle + 15 cm  
Remarque: L'idéal est que la hauteur du Duschpaneele soit adaptée à la taille corporelle du client en testant la position optimale par maintien et en marquant des repères. Veiller alors à ce qu'aucun tuyau ne soit plié ou écrasé. Lors du maintien, le Duschpaneele doit être raccordé afin de pouvoir détecter d'éventuelles collisions.

**nl**

Aansluitmaten niet bindend, omdat flexibele slangen variatiemogelijkheden bieden.  
Vuistregel: Onderzijde hoofddouche = lichaamslengte + 15 cm.  
Opmerking: In het ideale geval wordt de hoogte van de Duschpaneele aan de lichaamslengte van de klant aangepast door te meten en zo de optimale positie uit te proberen en dan te markeren. Daarbij moet erop gelet worden dat de slangen geen bochten hebben of in de knel zitten. De Duschpaneele moet bij het meten aangesloten zijn om mogelijke collisions te kunnen markeren.

# Benötigtes Werkzeug, Tools required, Outils nécessaires, Benodigd gereedschap

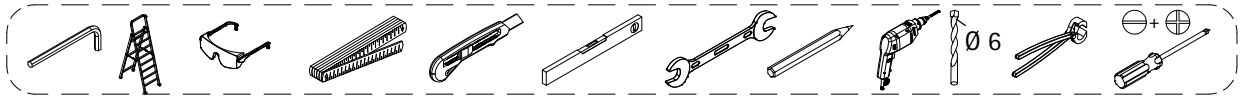

**1**

- de** Mit Hanf oder Dichtband vor dem Einschrauben eindichten!
- en** PTFE tape or hemp and bass white!
- fr** Bande en téflon ou filasse et pâte d'étanchéité!
- nl** Teflonband of hennep en afdichtingspasta!

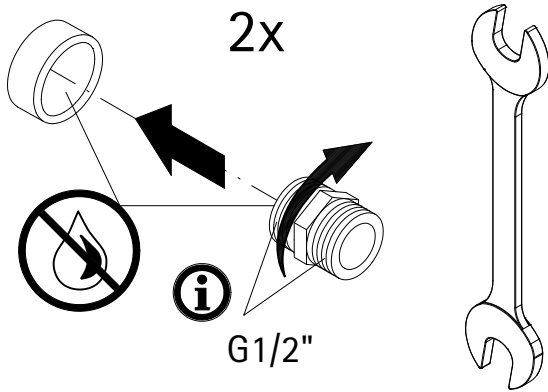

**2**

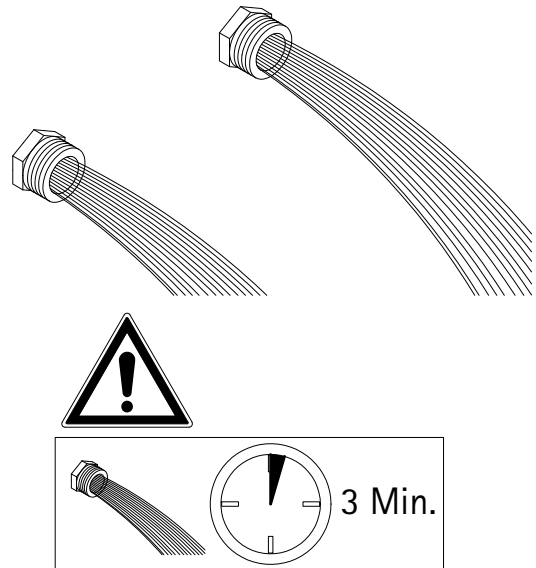

**3**

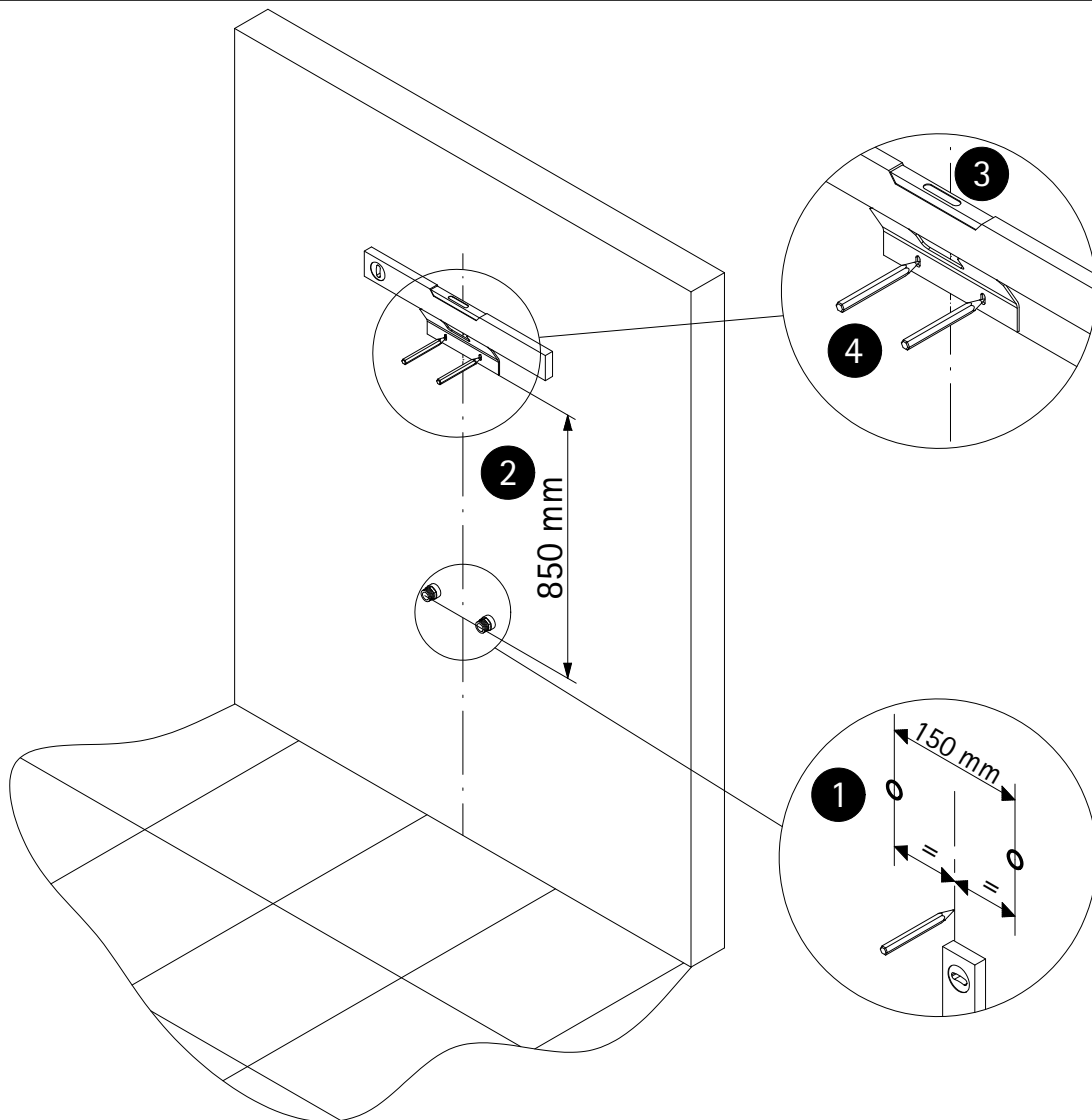

4

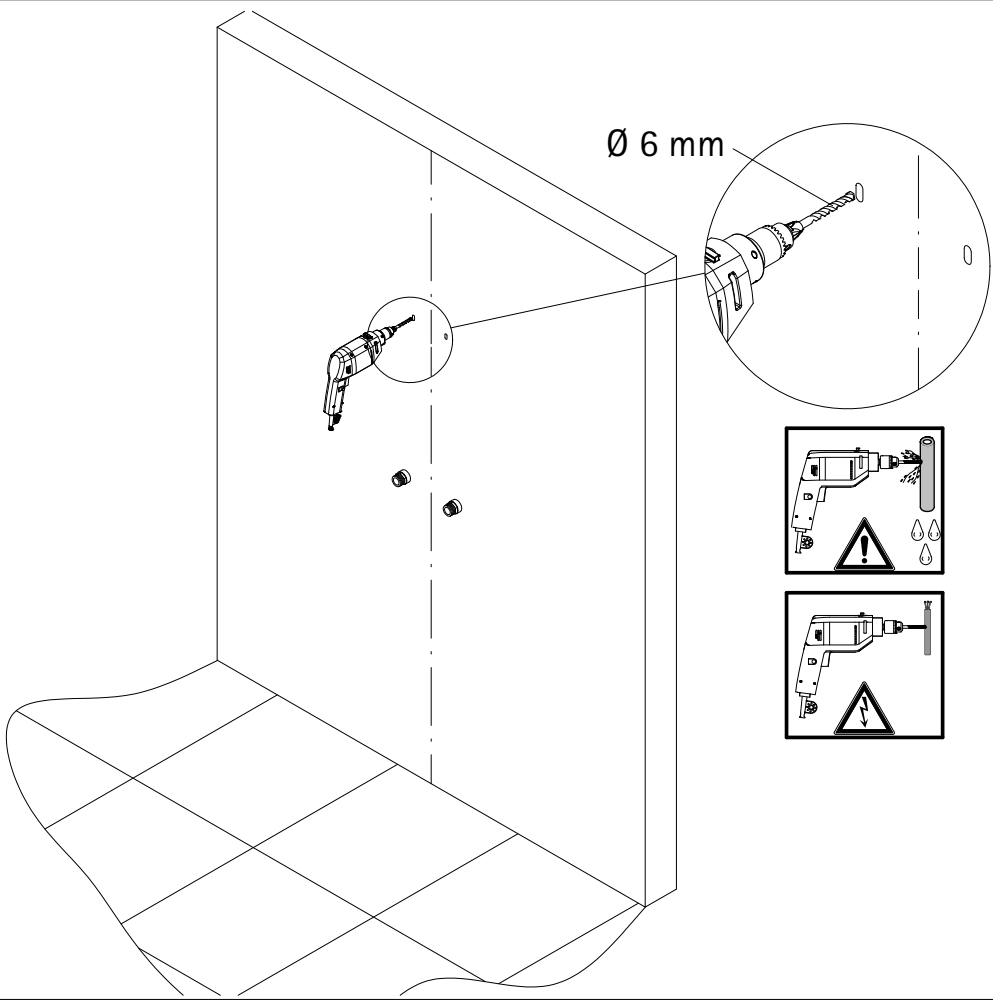

5

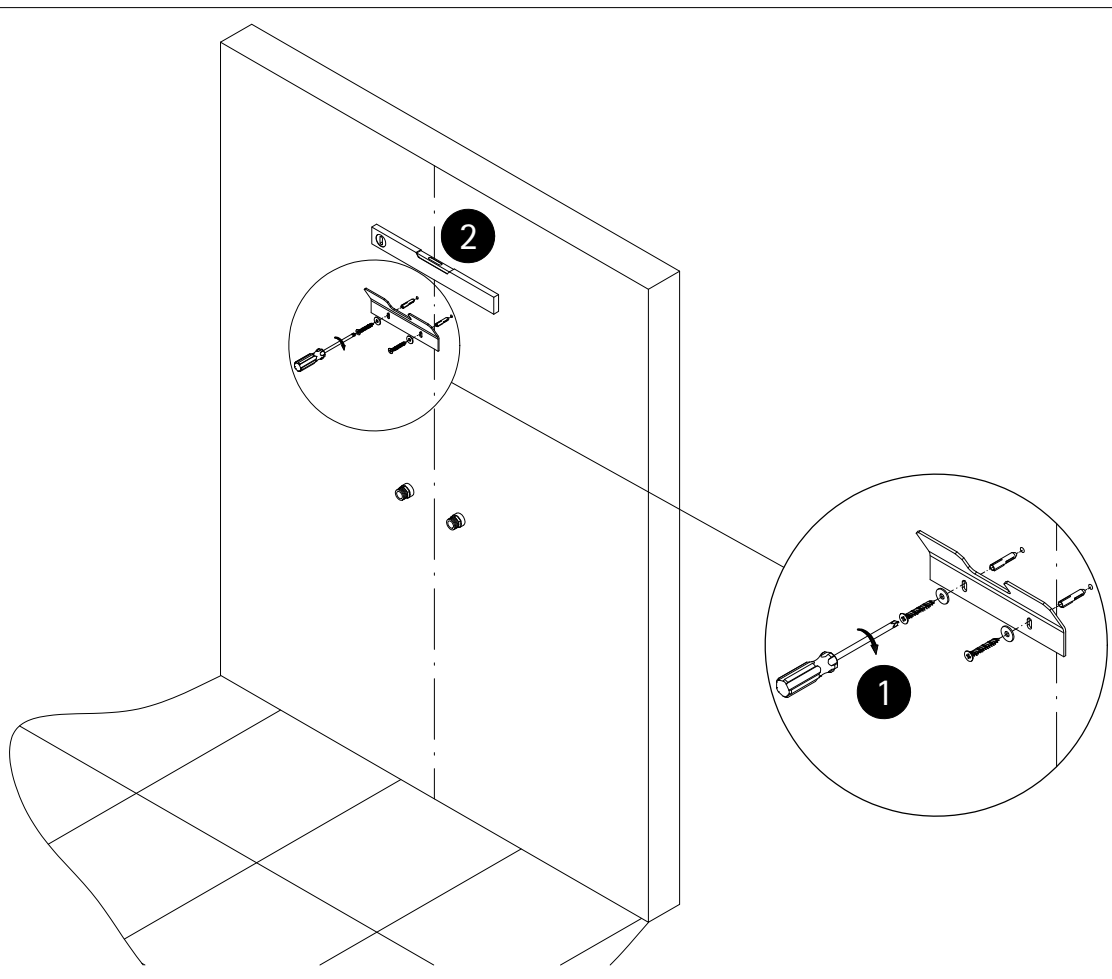

5

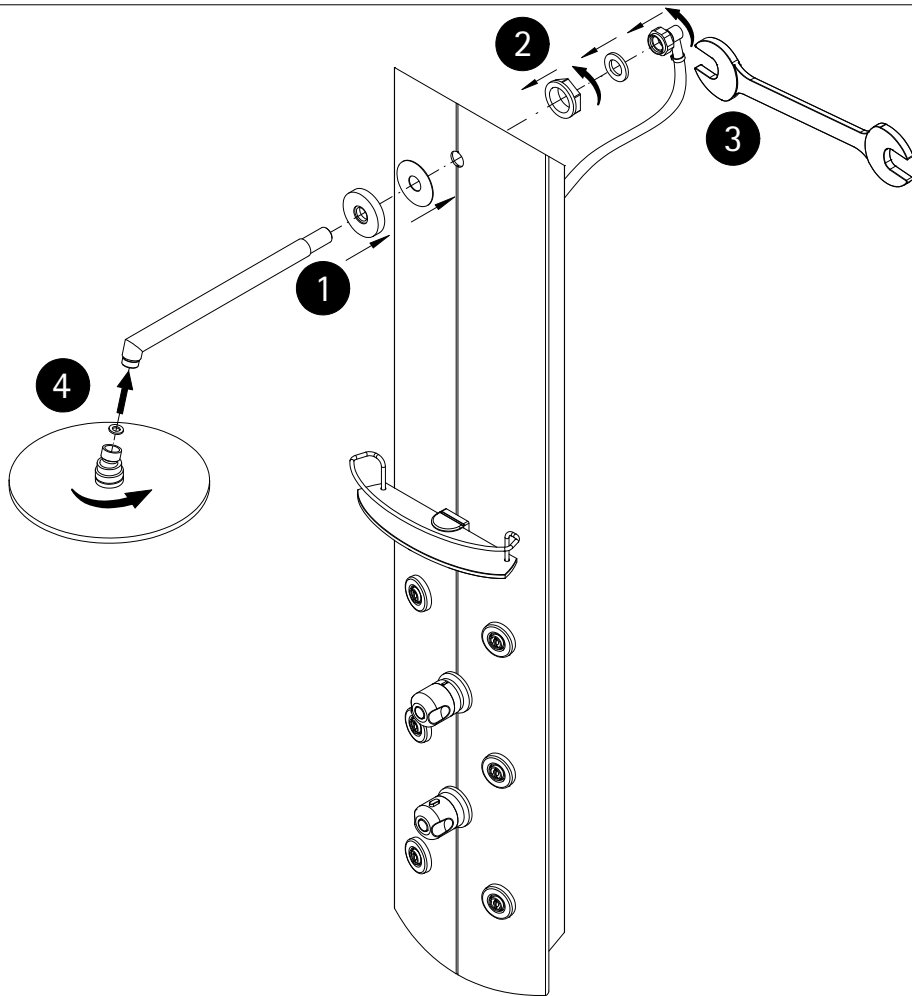

6

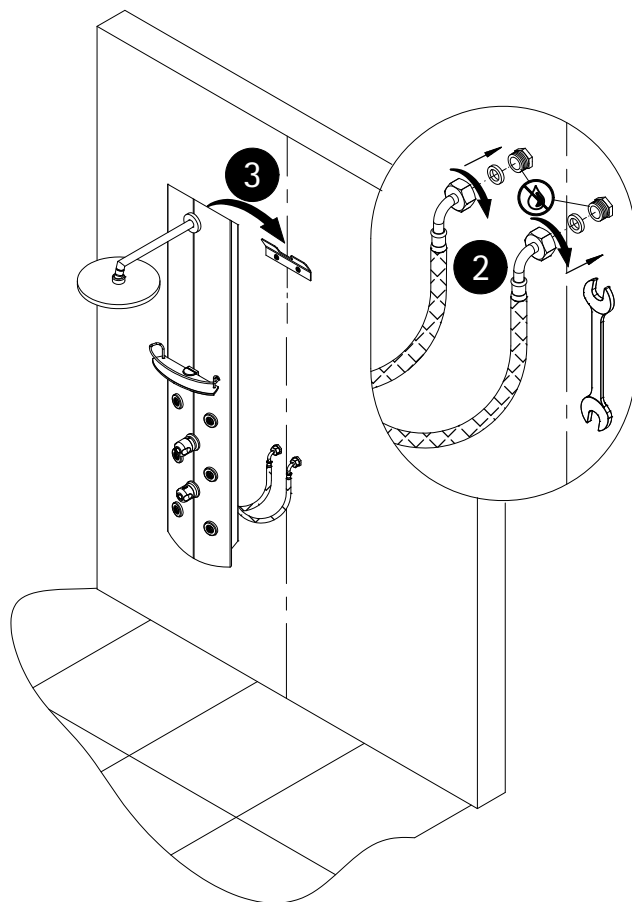
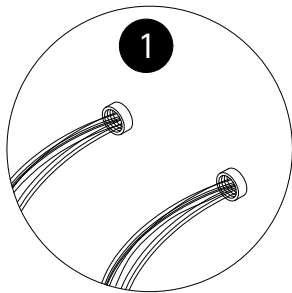

**de** Achtung !  
Vor der Montage Zuleitungen und Wasseranschlussgewinde gewissenhaft reinigen (Dichtungsreste entfernen) und spülen (bei geöffnetem Haupthahn ca. 3 Min. Wasser laufen lassen) da sonst Schmutzpartikel die Funktion des Duschpaneels beeinträchtigen!

**en** Note !  
Before assembly, clean the feed pipe and wall connection carefully (remove remains of joint packing) and rinse them out (allow the water to run with the main stopcock open for about 3 min.), otherwise dirt particles might affect the function of the showercolumn!

**fr** Attention !  
Avant le montage, nettoyer minutieusement la conduite d'alimentation et le filet de raccordement mural (enlever les restes de joints) et rincer, (laisser couler de l'eau pendant environ 3 minutes avec le robinet principal ouvert) sans quoi des particules de saleté risquent d'affecter le fonctionnement de colonne de douche!

**nl** Let op !  
Maak vóór de montage toevoer en wandschroefdraad-verbinding zorgvuldig schoon (verwijder de afdichtingrestanten) en laat er water doorlopen (ca. 3 min. bij open hoofdkraan), omdat anders vuildeeltjes de werking van de douchepaneel schaden!

7

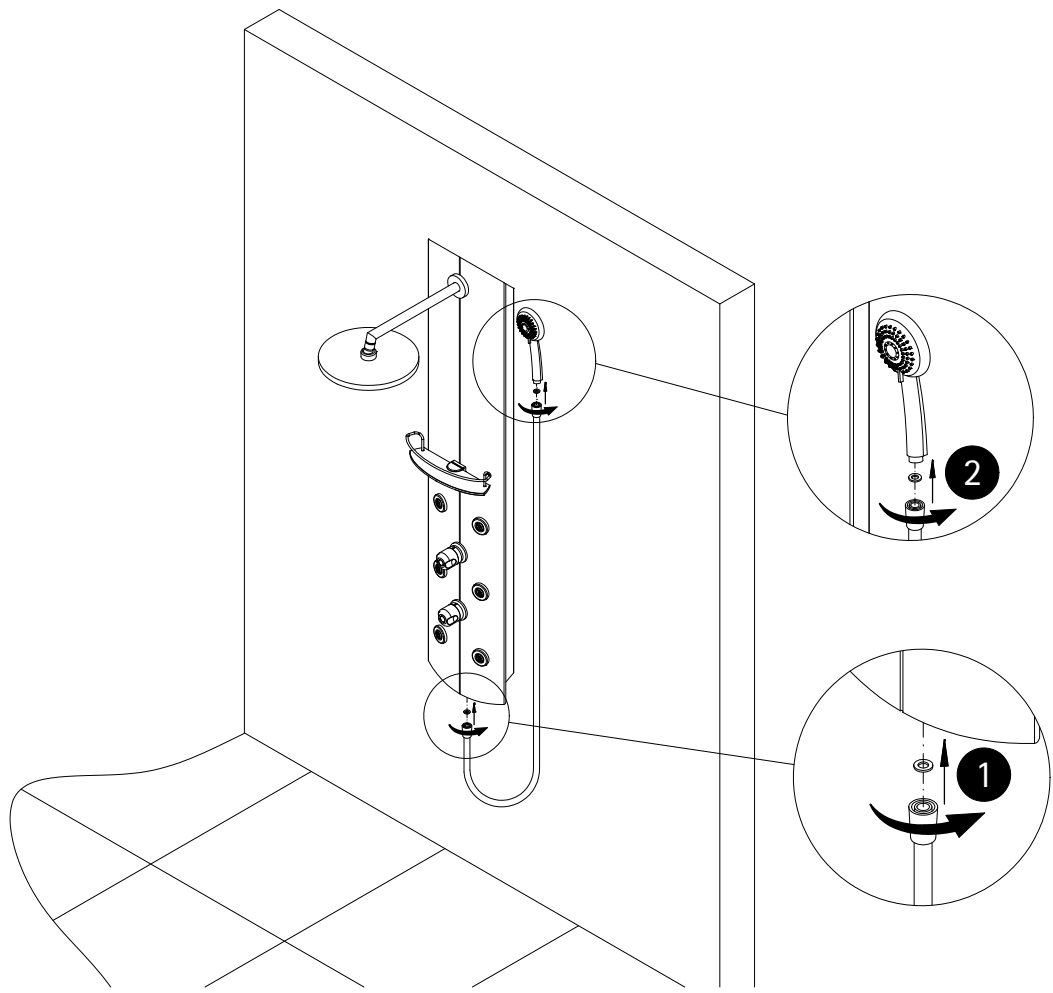

8



Ansicht von innen!  
viewing from inside!  
visionnement de l'intérieur!  
het bekijken van binnen!

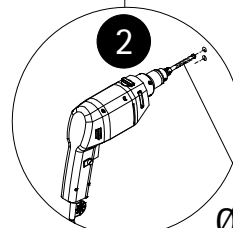
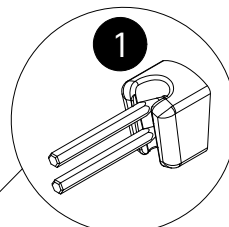
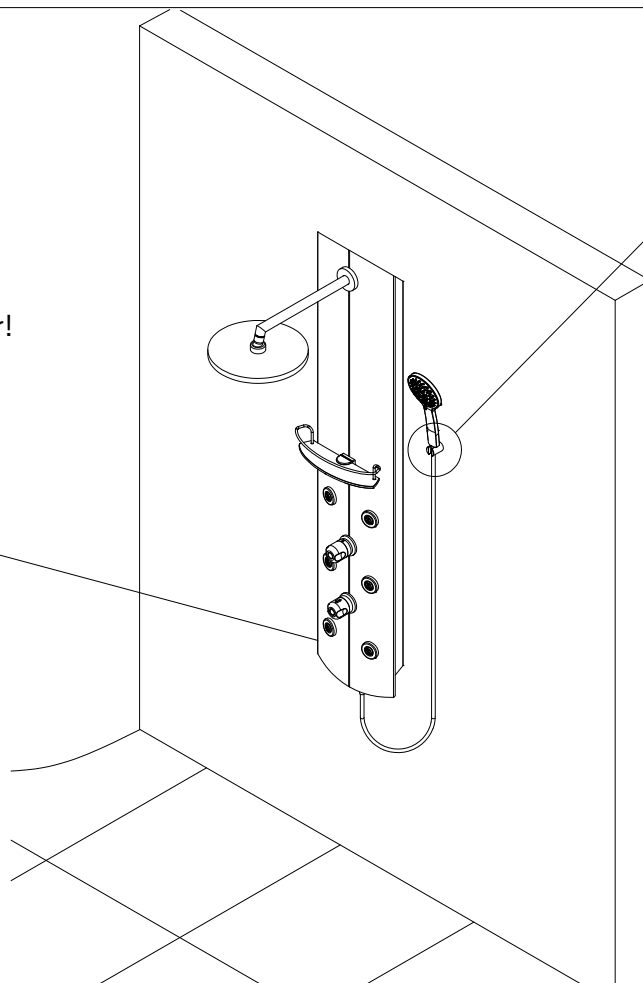
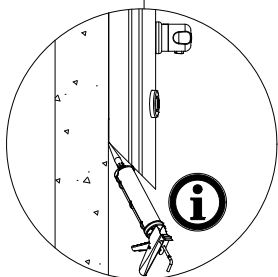
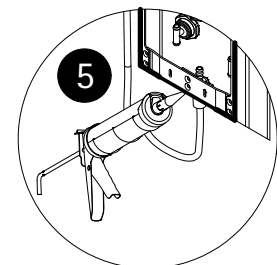

Ø 6 mm

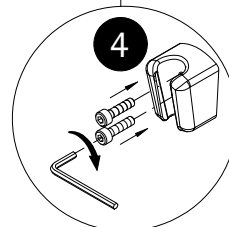
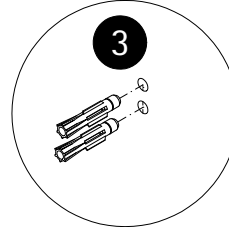



**Info**

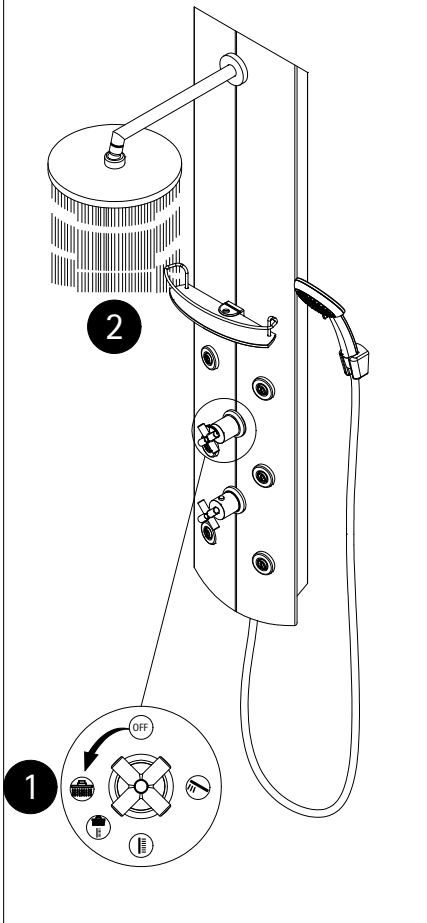

**Info**

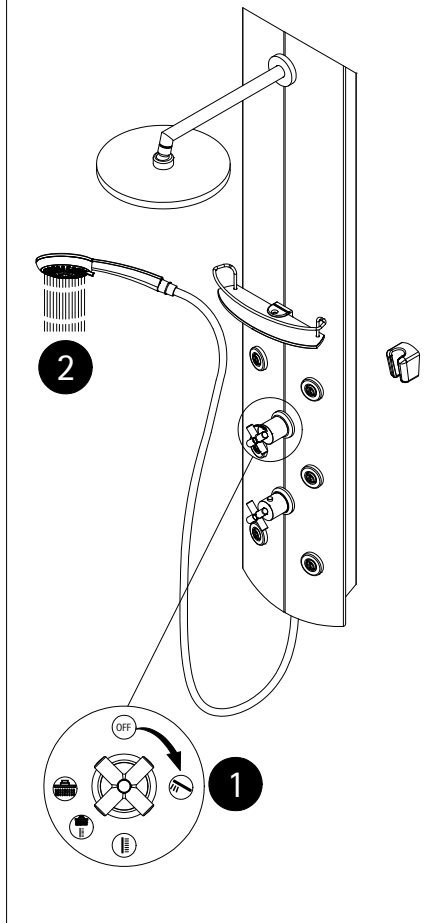

**Info**

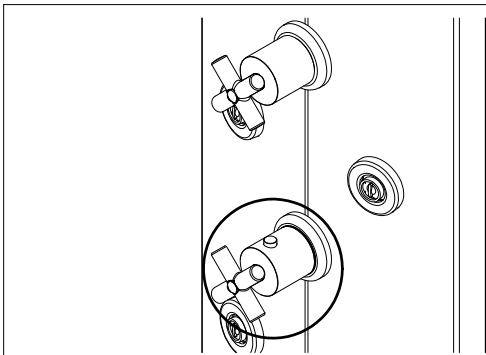
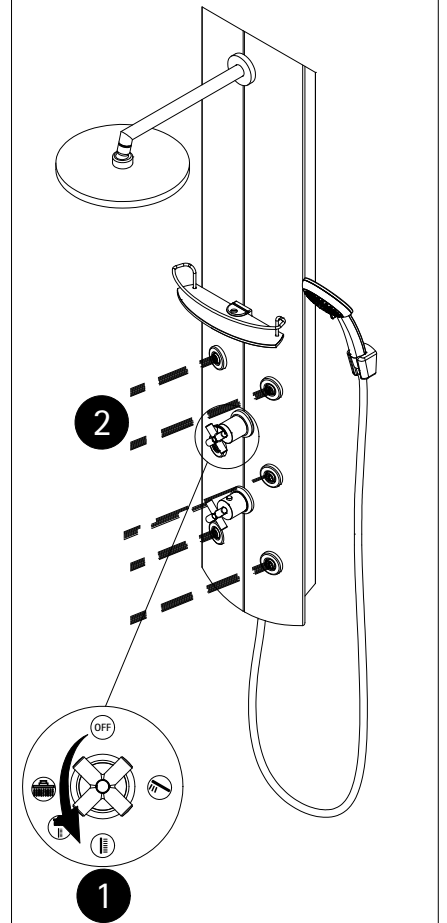

**Info**

**de** kalt ☀ / warm ❄

**en** cold ☀ / hot ❄

**fr** froid ☀ / chaud ❄

**nl** koud ☀ / warm ❄

**Info**

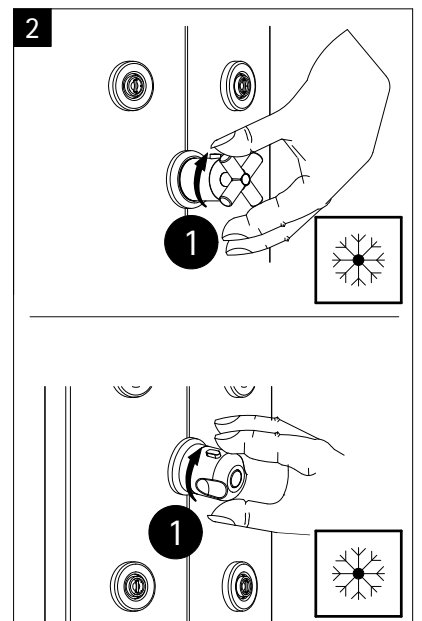
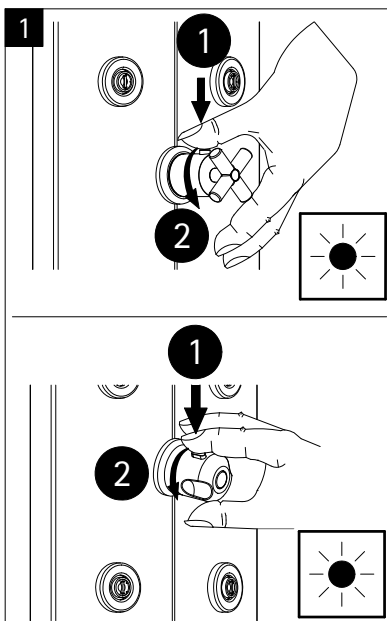
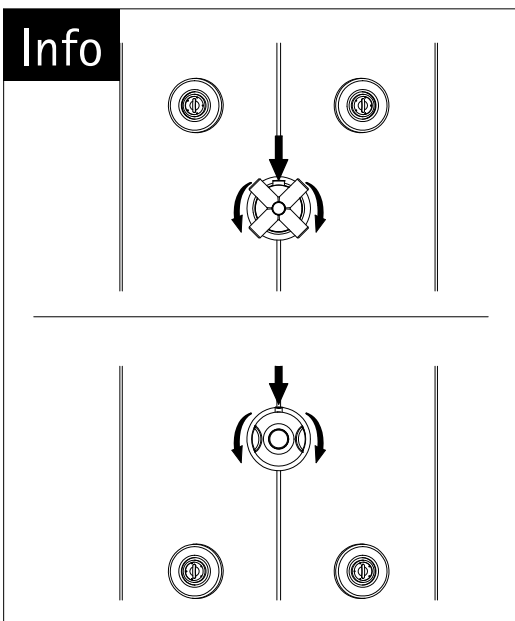

## Info

- de** Temperatureinstellung.
- en** temperature adjustment.
- fr** réglage de la température
- nl** temperatuurinstelling.

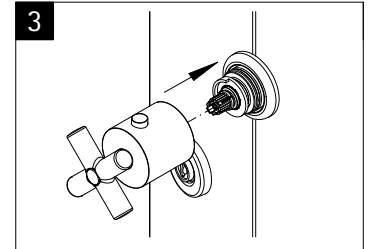
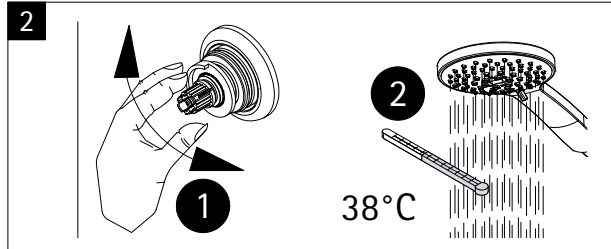
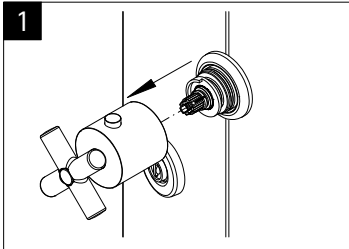
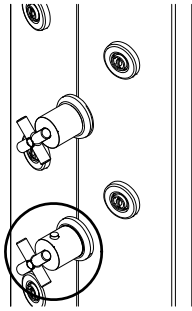

## Info

- de** Ablage ganz / teilweise tauschen  
Wasser abstellen!
- en** exchange tray completely / partially  
turn of the water!
- fr** échanger le rack complètement / partiellement  
couper l'arrivée d'eau!
- nl** rek ruilen geheel / een deel  
water afsluiten!

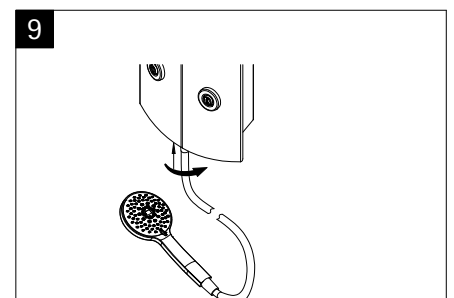
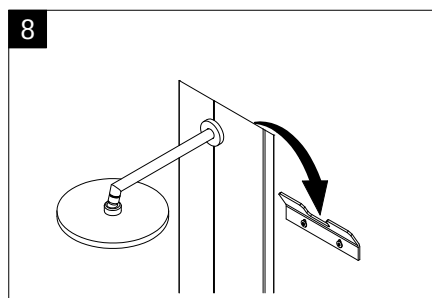
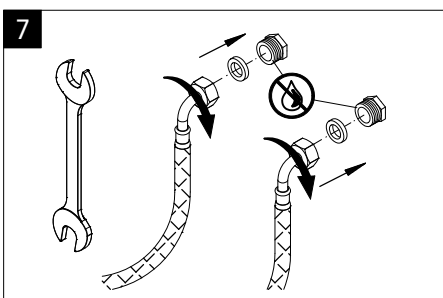
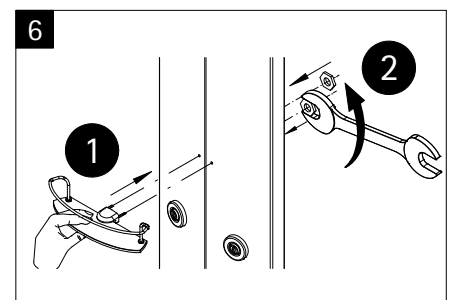
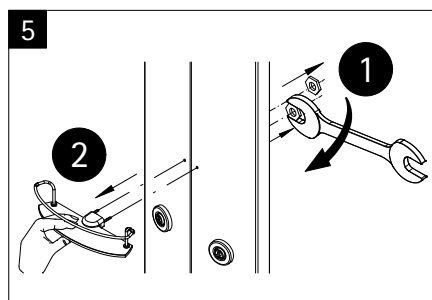
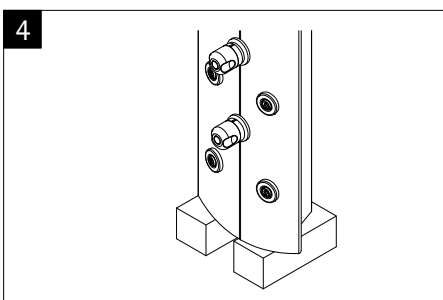
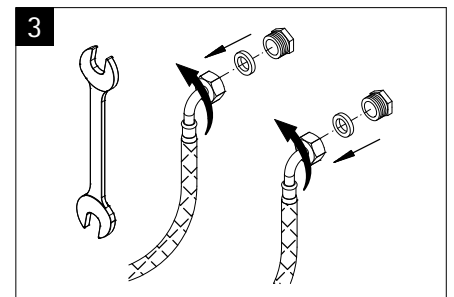
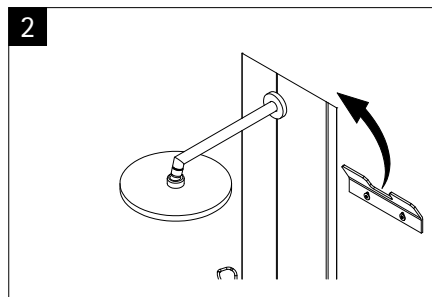
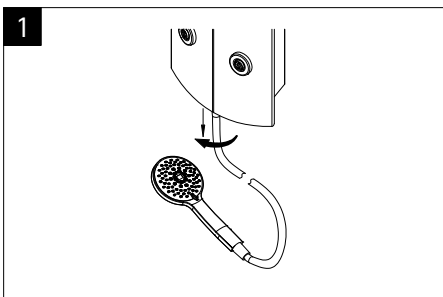
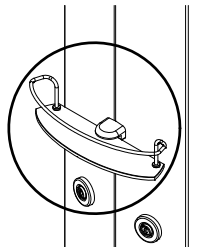

# Info

de

Umstellerkartusche wechsell.  
Wasser abstellen!

en

Change umstellers cartridge.  
turn of the water!

fr

changer la cartouche de contrôle.  
couper l'arrivée d'eau!

nl

Verwissel het controlepatroon.  
water afsluiten!

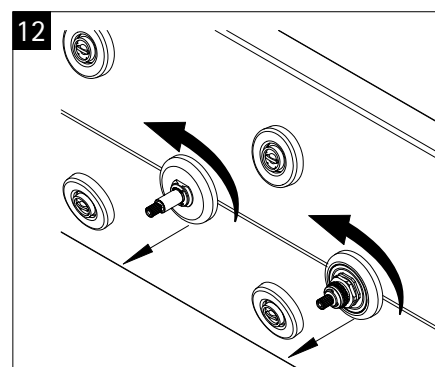
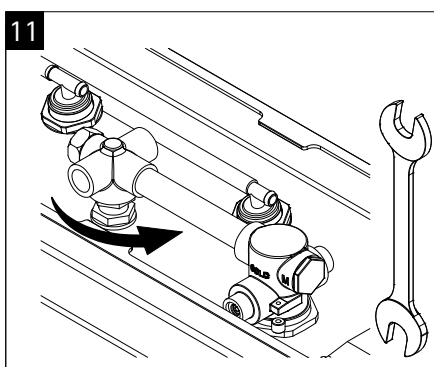
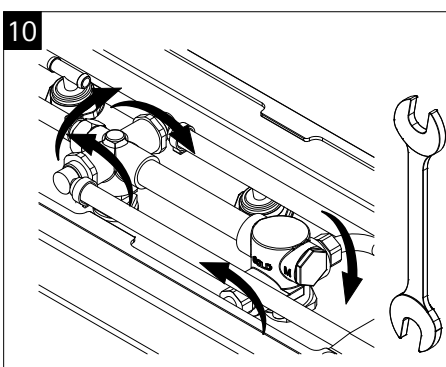
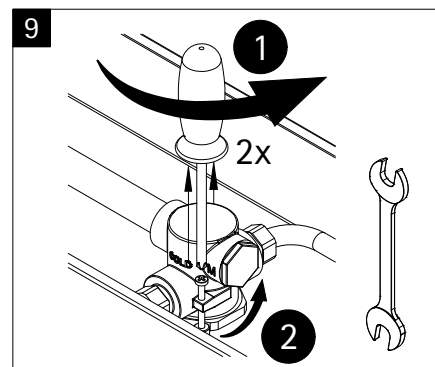
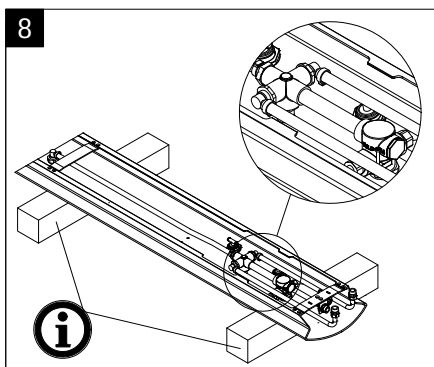
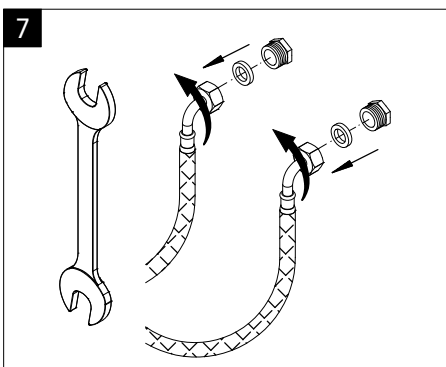
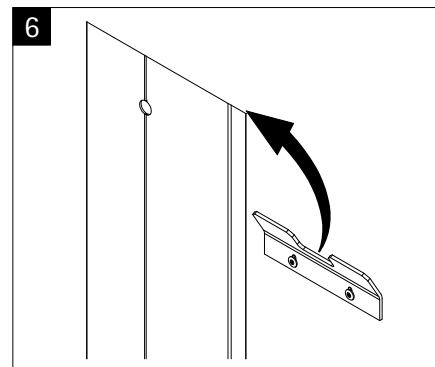
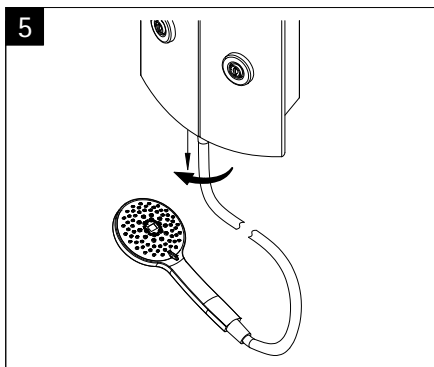
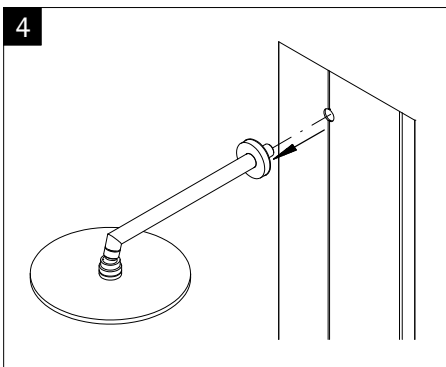
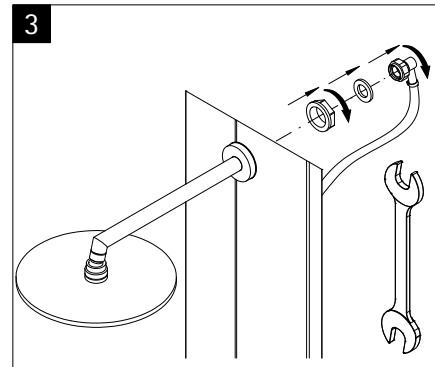
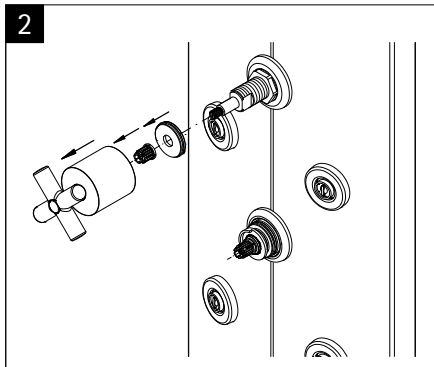
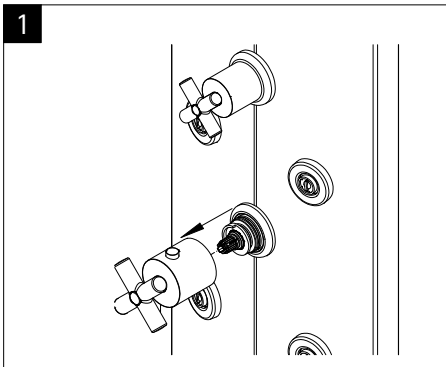
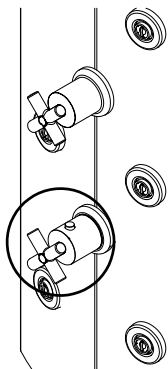

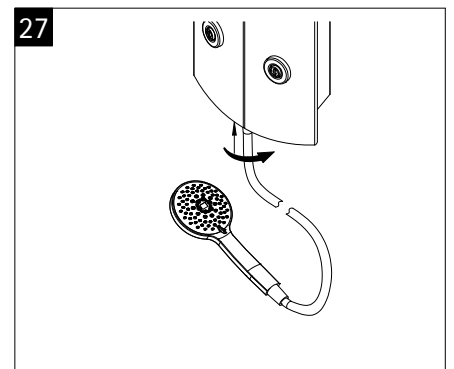
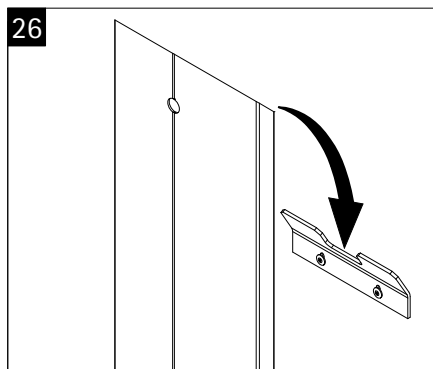
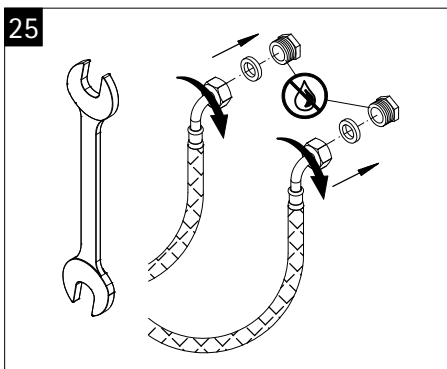
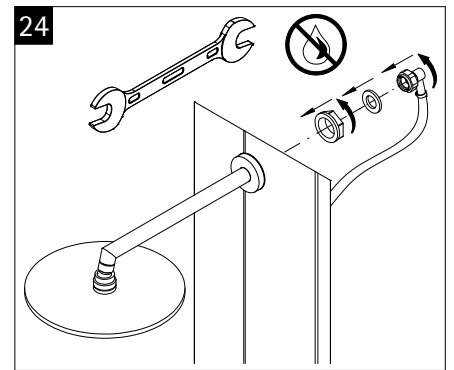
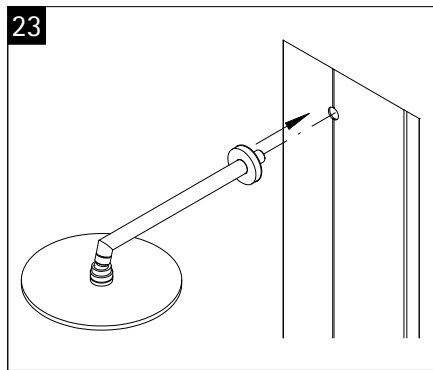
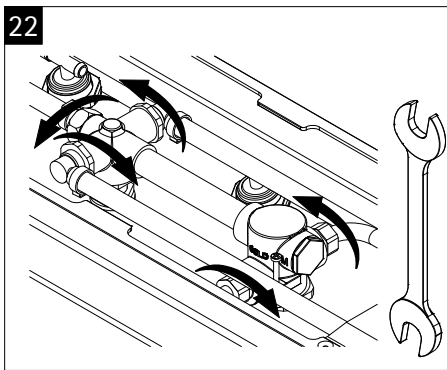
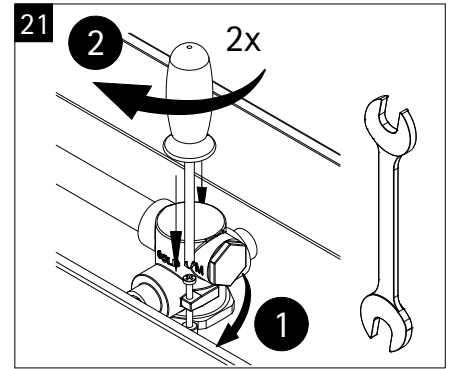
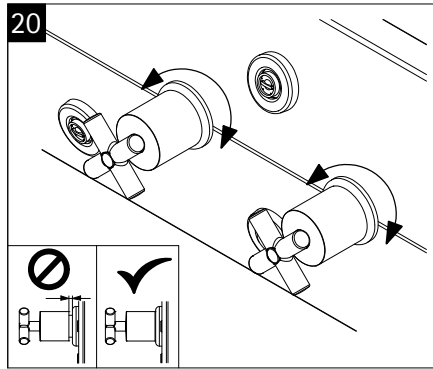
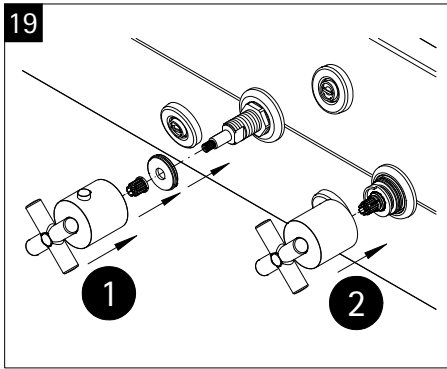
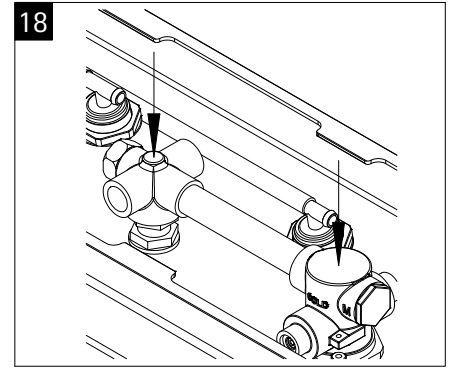
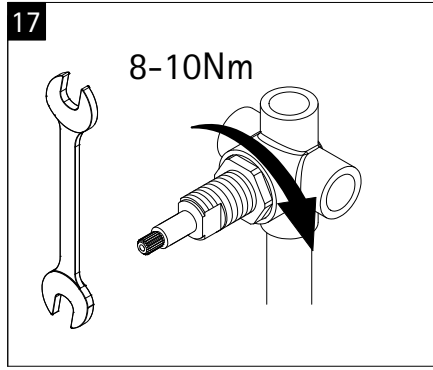
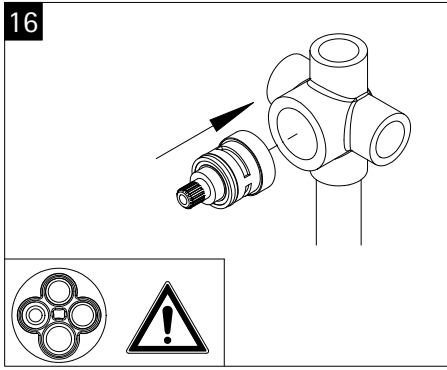
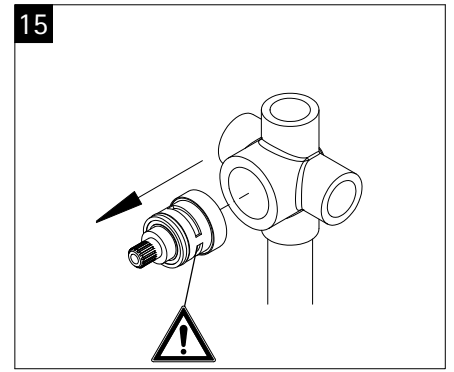
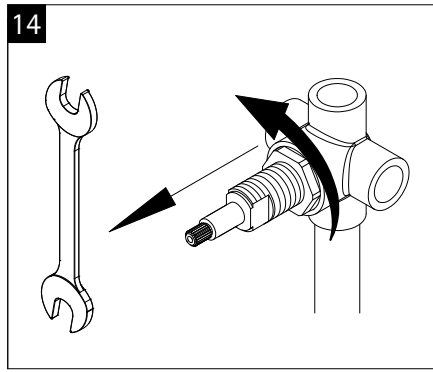
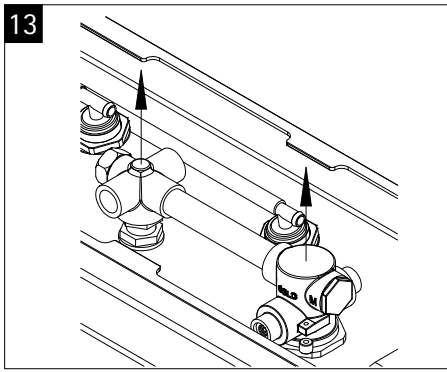

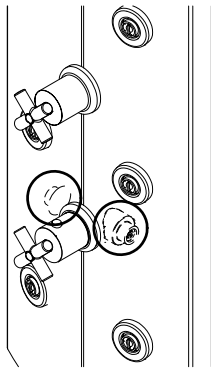

## Info

- de** Rückflussverhinderer warten.  
Wasser abstellen!
- en** maintain non-return valve  
Turn of the water!
- fr** entretien du clapet anti-retour.  
Couper l'arrivée d'eau!
- nl** terugslagklep onderhouden.  
Water afsluiten!

## Info

- de** Schritt 1-12 siehe Seite 11
- en** Step 1-12 see page 11

- fr** Étapes 1à 12, voir page 11
- nl** Stap 1-12 zie blz. 11

13

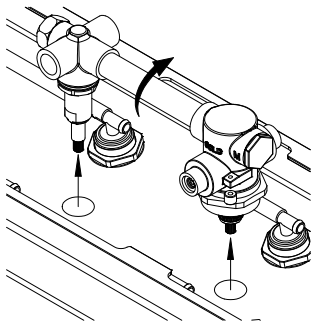

14 # optional

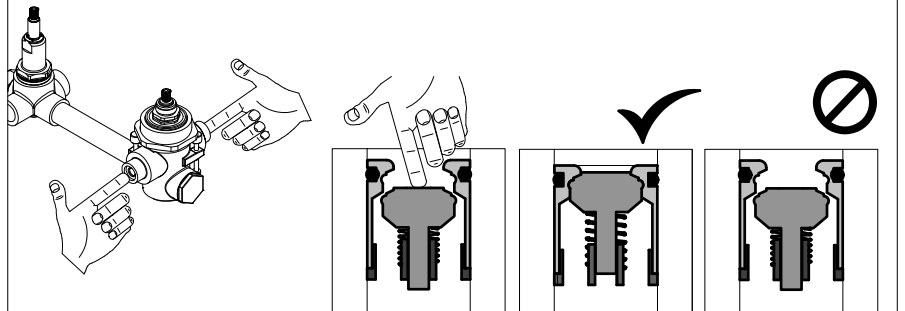

16

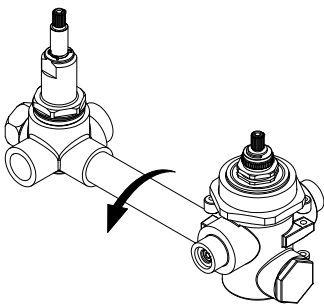

17

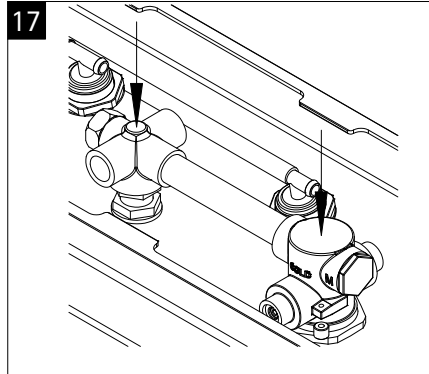

18

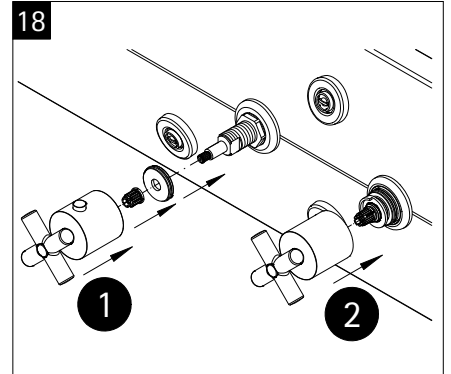

19

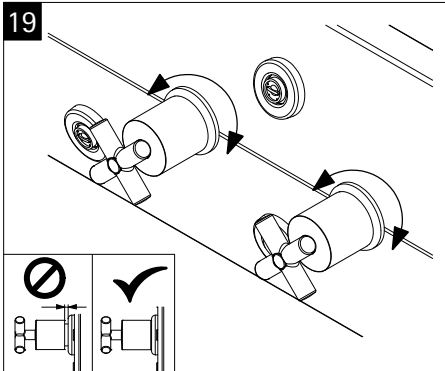

20

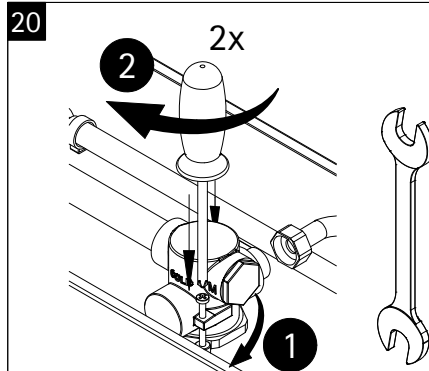

21

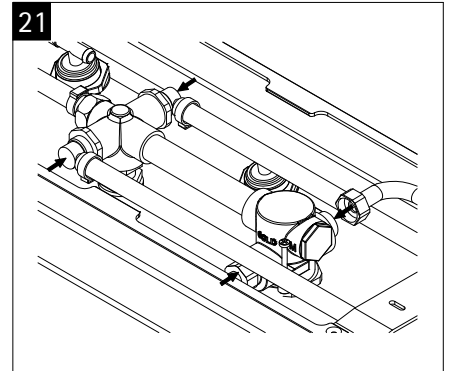

## Info

- de** Schritt 22-27 siehe Seite 12
- en** Step 1-12 see page 12

- fr** Étapes 22à 27, voir page 12
- nl** Stap 22-27 zie blz. 12

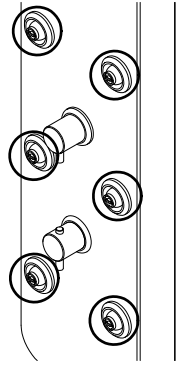

## Info

- de** Massagedüse wechseln.  
Wasser abstellen!
- en** exchange massage jet  
Turn of the water!
- fr** échanger la buse de massage  
Couper l'arrivée d'eau!
- nl** massage mondstuk ruilen  
Water afsluiten!

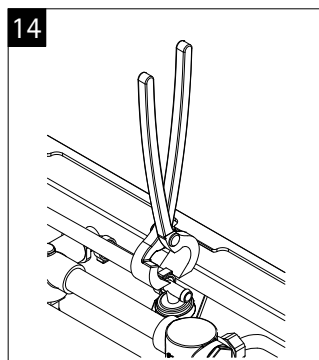
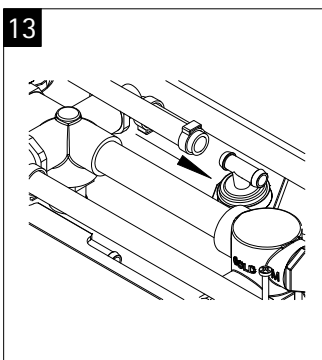
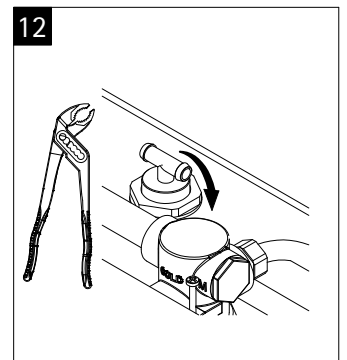
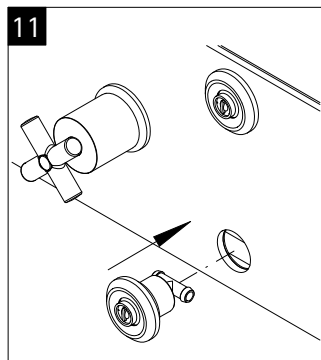
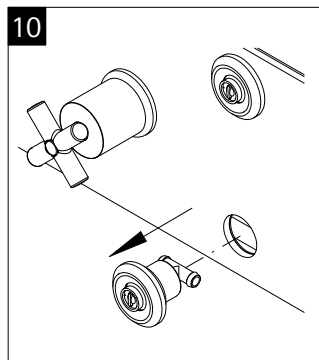
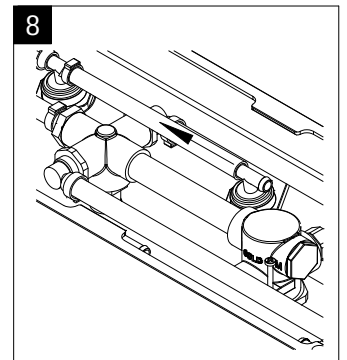
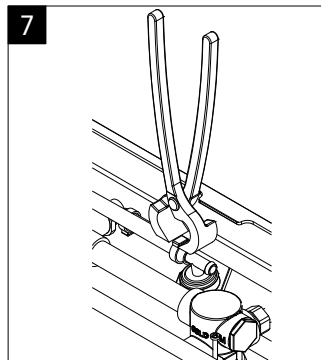
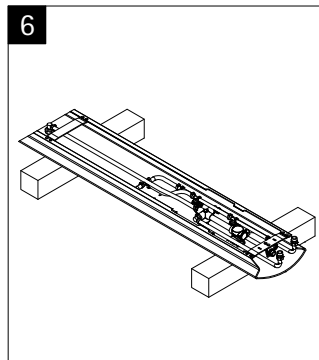
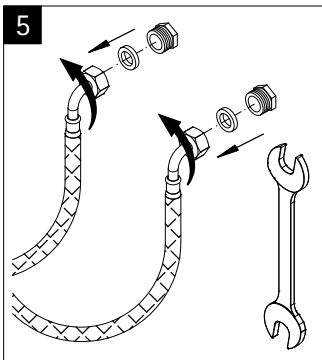
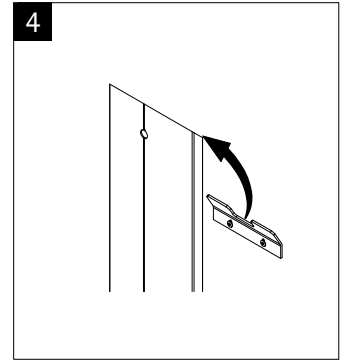
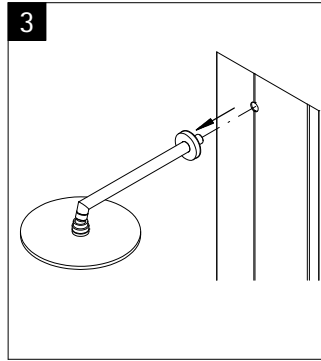
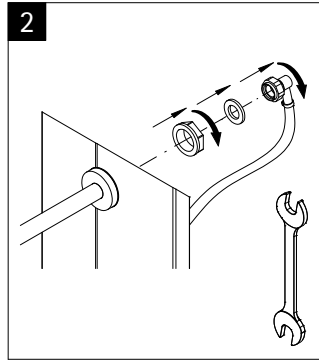
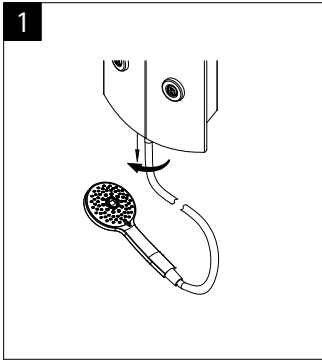

## Info

- de** Einbau in umgekehrter Reihenfolge.
- en** Installation in the reverse order.
- fr** Montage dans le sense inverse.
- nl** Inbouw in omgekeerde volgorde.

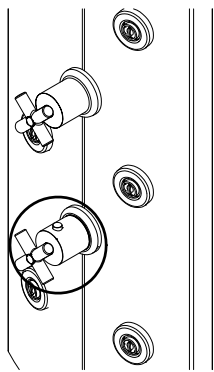

## Info

- de** Thermostatkartusche wechseln.  
Wasser abstellen!
- en** change the thermostat cartridge.  
turn off the water!
- fr** changez la cartouche du thermostat.  
couper l'arrivée d'eau!
- nl** eenhendelmenkraan wisselen.  
water afsluiten!

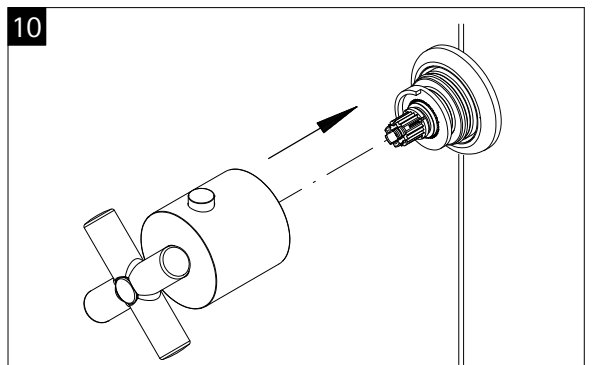
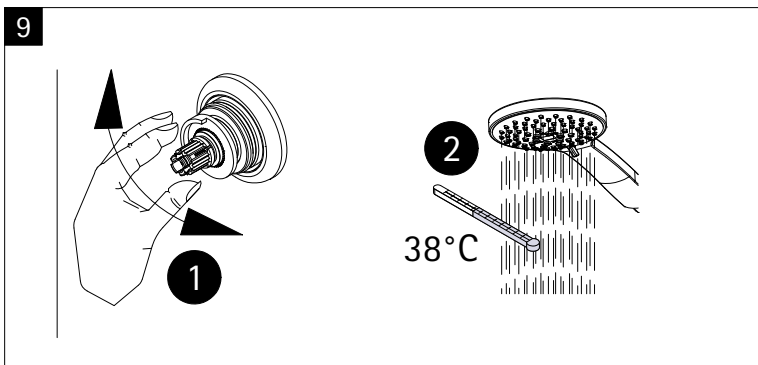
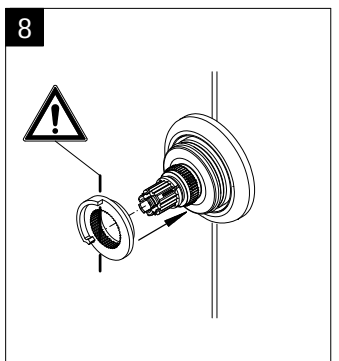
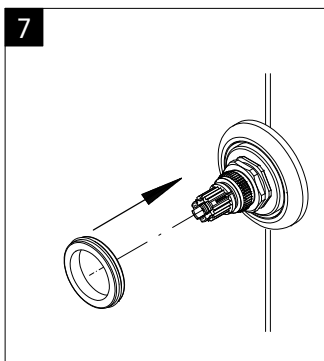
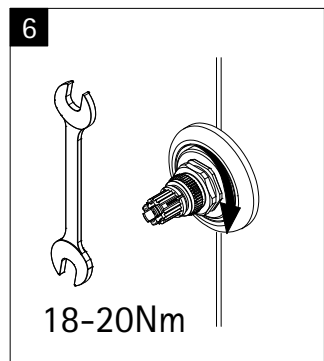
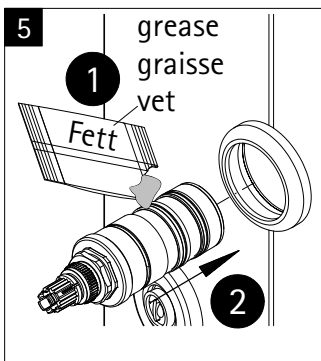
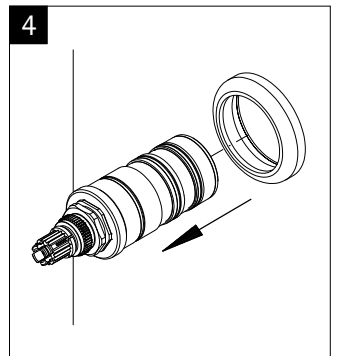
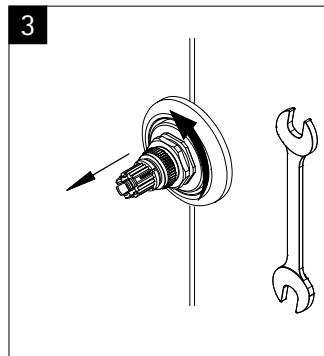
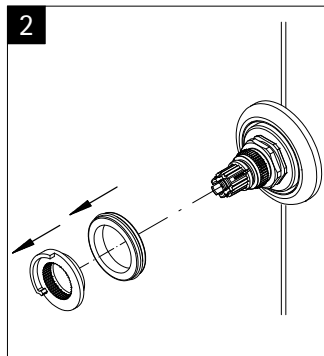
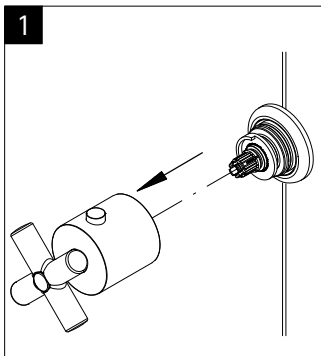

## Info

- de** Tropfende Brausen: Hand- und Kopfbrause
- en** dripping head or hand shower
- fr** pommeau haut ou dochette à main goutent
- nl** druipende dochekop of handdoche

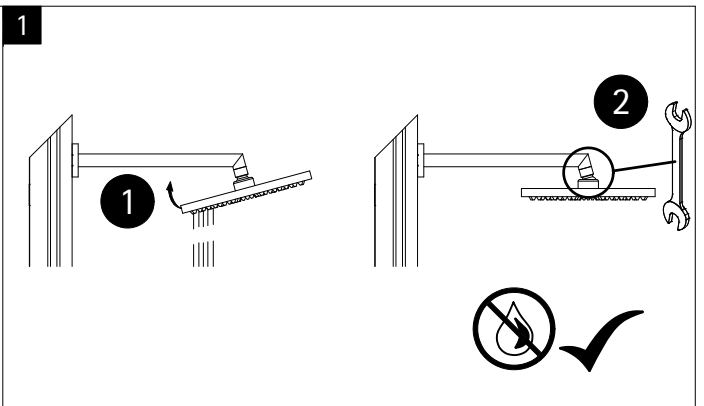

4112-8

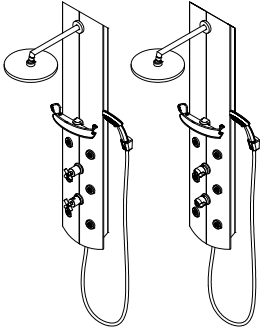

Prüfnummer / Inspection number / Numéro d'essai / Testnummer



Ersatzteilbestellung / spare parts order  
commande de pièces de rechange / Bestelling van reserveonderdelen:  
Fax 02962 / 972-4260



Technische Hilfe / technical help / l'aide technique / technologische ondersteuning  
Telefon 02962 / 972-40



E-Mail:  
[ersatzteile@duschservice.de](mailto:ersatzteile@duschservice.de)



Duschservice  
Zum Hohlen Morgen 22  
59939 Olsberg  
Deutschland / Germany / Allemagne / Duitsland



000060503000000000000000